



## Avonic PTZ Camera 20x/12x/30x zoom

CM70-IP / CM71-IP / CM73-IP

# CONTENTS

---

<b>Introduction.....</b>	<b>3</b>
Contact .....	3
Join Avonic .....	4
<b>Safety Notes.....</b>	<b>5</b>
<b>Package contents and Accessories.....</b>	<b>7</b>
Contents.....	7
Handling precautions .....	7
Accessories .....	7
<b>Product Overview.....</b>	<b>8</b>
Features .....	8
<b>Installation .....</b>	<b>9</b>
Connections .....	9
System Select Switch.....	10
RS232 Interface.....	10
RS232 network connection diagram .....	11
RS485 network connection diagram .....	11
IP network connection diagram.....	11
<b>Serial Communication Control .....</b>	<b>12</b>
COM port settings.....	12
IP Control.....	12
<b>Operation.....</b>	<b>13</b>
Remote controller .....	13
Other Key Combinations .....	15
<b>OSD Menu .....</b>	<b>16</b>
<b>WebGUI.....</b>	<b>21</b>
Login.....	21
Local.....	21
Audio .....	22
Video .....	23
Network.....	37
System .....	38
<b>Maintenance .....</b>	<b>43</b>

Camera Maintenance .....	43
Unauthorized Use .....	43
<b>Troubleshooting.....</b>	<b>43</b>
General Advice .....	43
Power Issues.....	43
Image.....	44
Control .....	44
WebGUI.....	44
<b>Appendix A - VISCA Settings and command list.....</b>	<b>45</b>
Visca over IP .....	45
<b>Appendix B - Dimensions.....</b>	<b>57</b>
<b>Appendix C - HTTP API.....</b>	<b>58</b>
<b>CMOS Image Sensors Characteristics.....</b>	<b>72</b>

# INTRODUCTION

---

Thank you for your Avonic purchase. Before operating this product, please read the manual thoroughly and retain it for future reference. The manual can be downloaded on [www.avonic.com](http://www.avonic.com). Save this manual for future reference.

## CONTACT

For any questions or suggestions, contact your reseller or the local distributor of Avonic. Find the local distributor on the website of Avonic. For the most recent version of the manual or datasheet, look at the Avonic website: [www.avonic.com](http://www.avonic.com).

## JOIN AVONIC



[www.Facebook.com/  
avonicPTZ](http://www.Facebook.com/avonicPTZ)



[www.Linkedin.com/company/  
avonic](http://www.Linkedin.com/company/avonic)



[www.twitter.com/  
avonic](http://www.twitter.com/avonic)

# SAFETY NOTES

---

## Important safety information

**⚠ WARNING:** Failure to follow these safety instructions could result in fire, electric shock, injury, or damage to this Product or other property. Read all the safety information below before using this Product.

**⚠ WARNING:** Before operating this product, please read the manual thoroughly and retain it for future reference. The manual can be downloaded on [www.avonic.com](http://www.avonic.com).

## Handling

Handle this Product with care. It is made of metal, glass, and plastic and has sensitive electronic components inside. This Product can be damaged if dropped, burned, punctured, or crushed, or if it comes in contact with liquid. If you suspect damage to this Product, discontinue use of this Product, as it may cause overheating or injury.

**⚠ WARNING:** Do not pick up and move the unit while a tripod is attached. The fitting may break under the weight of the tripod, which may result in injury.

## Installation

Set up this Product on a hard, stable surface or mount it to a wall or ceiling. Only use an Avonic mount for mounting to a wall or ceiling. Ensure the mounting construction is capable of supporting four times the weight of the equipment downwards. Make sure to make use of a safety loop or drop protection that is capable of preventing the Product from falling if the mounting construction fails. Never install a product above persons to prevent any risk on injuries when it falls down.

**⚠ WARNING:** In order to maintain adequate ventilation, do not install or place this unit in a bookcase, built-in cabinet or any other confined space. To prevent risk of electric shock or fire hazard due to overheating, ensure that curtains and any other materials do not obstruct the ventilation.

**⚠ WARNING:** Check the installation at least once a year. An improper installation could cause the unit to fall off resulting in personal injury.

## Repairing

Don't open this Product and don't attempt to repair this Product yourself. Disassembling this Product may damage it or may cause injury to you. If this Product is damaged, malfunctions, or comes in contact with liquid, contact Avonic or an Avonic Authorized Service Provider. Repairs by service providers other than Avonic or an Avonic Authorized Service Provider may not involve the use of Avonic genuine parts and may affect the safety and functionality of the device. You can find more information about repairs and service at [www.avonic.com](http://www.avonic.com).

## Power

Power this Product with the included cable and power adapter. Other adapters may not meet applicable safety standards, and connecting with such adapters could pose a risk of death or injury.

**⚠ WARNING:** Using damaged cables, or using the Product when moisture is present, can cause fire, electric shock, injury, or damage to this Product or other property. When you power this Product, make sure the cable is fully inserted into the power adapter before you plug the adapter into a power outlet. It's important to keep this Product, the cable, and the power adapter in a well-ventilated area when in use.

### **Power adapter**

To operate the Avonic power adapter safely and reduce the possibility of heat-related injury or damage, plug the power adapter directly into a power outlet. Don't use the power adapter in wet locations, and don't connect or disconnect the power adapter with wet hands. Stop using the power adapter and any cables if any of the following conditions exist:

- The power adapter plug or prongs are damaged.
- The cable becomes frayed or otherwise damaged.
- The power adapter is exposed to excessive moisture, or liquid is spilled into the power adapter.
- The power adapter has been dropped, and its enclosure is damaged.

### **Intended use**

This Product shall not be used in the residential area and shall only be installed and operated by experienced technicians.

### **Not a medical device**

This Product is not a medical device and should not be used as a substitute for professional medical judgment. It is not designed or intended for use in the diagnosis of disease or other conditions, or in the cure, mitigation, treatment, or prevention of any condition or disease. Please consult your healthcare provider prior to making any decisions related to your health.

### **Explosive and other atmospheric conditions**

Using this Product in any area with a potentially explosive atmosphere, such as areas where the air contains high levels of flammable chemicals, vapours, or particles (such as grain, dust, or metal powders), may be hazardous. Exposing this Product to environments having high concentrations of industrial chemicals, including near evaporating liquified gasses such as helium, may damage or impair this Product functionality. Obey all signs and instructions.

### **High-consequence activities**

This device is not intended for use where the failure of the device could lead to death, personal injury, or severe environmental damage.

# PACKAGE CONTENTS AND ACCESSORIES

## Contents

Quantity	Description	Avonic SKU
1 pc	PTZ Camera	AV-CM70/71/73-IP-B/W
1 pc	Power Supply 12V/A	AV-CM40-PSU
1 pc	Remote Control	AV-CM40-RC
1 pc	USB cable type A to type A	AV-USB20-AA
1 pc	RS232 9-pin male to 8-pin male	AV-CM-RS232
1 pc	2-way RS485 serial connector	AV-PHNX-2
1 pc	5-way Balanced audio conn.	AV-PHNX-5

## Handling precautions

Be cautious to take the camera by its base. When placing back the camera in its protective foam, be sure the lens is in horizontal position.

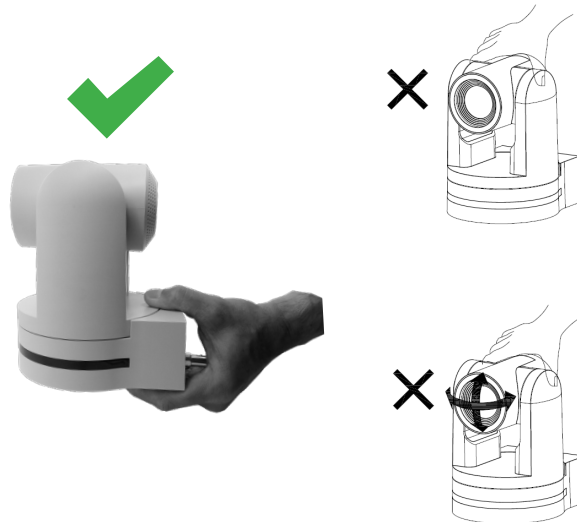

## Accessories



Ceiling mount  
SKU white: AV-MT250-W  
SKU black: AV-MT250-B



Wall and Ceiling mount  
SKU white: AV-MT200-W  
SKU black: AV-MT200-B

# PRODUCT OVERVIEW

---

The Avonic CM70 series is a high quality PTZ camera line with simultaneous HDMI, 3G-SDI, USB 2.0 and IP stream ethernet outputs. The cameras are designed for fixed installations in less than optimal light conditions. The CM70 series includes a rich featureset usually found on broadcast-grade cameras, including a user-adjustable Colour Matrix and SRT streaming (licensed premium functions). The CM70 series has the ability to deliver outstanding quality under low light conditions, thanks to its high SNR CMOS sensor. The sensor delivers Full HD 1080p60 video

## Features

- 20x/12x/30x Optical Zoom, glass lens.
- High SNR CMOS combined with digital noise reduction for a clear picture even under very low light conditions.
- The camera has a Full HD resolution of 1920 x 1080p60 and achieves a pristine image quality.
- The camera can be powered using ethernet port with PoE (802.3af) functionality and can be accessed by webGUI, controlled by VISCA over IP/ Onvif and stream the video.
- H265, H264, optional SRT and MJPEG compression at a bitrate up to 40Mbit enabling Full HD video stream by ultra-low latency over RTSP, RTMP, UDP, Unicast, Multicast and NDI®| HX support.
- 3G-SDI, HDMI, USB 2.0 (1080p30) and IP.
- Control the camera with common protocols: VISCA , Pelco-D/P via RS232, RS485, IP(VISCA), Onvif or IR, remote control included. Supports up to 255 presets with 0.1° accuracy and High Speed Pan Tilt function.
- Balanced audio input with embedding into IP stream, SDI and HDMI outputs. Includes configurable audio offset.
- Optional premium features: SRT streaming, Tally light, configurable Color Matrix. License AV-LC70-1 sold separately.



# INSTALLATION

## Connections



1. Kensington Lock
2. Balanced Audio Line in 5-pin Phoenix connector
3. RS-485 two-wire serial communication with 2-pin Phoenix connector
4. System Selector (see Installation for more details)
5. RS-232 mini-DIN-8 IN (connect the supplied RS-232 cable)
6. RS-232 mini-DIN-8 OUT for daisy chaining RS-232 connection
7. 3G-SDI video output SMTPE 425M level B compliant
8. HDMI Type A
9. USB2.0 Type A, UVC video output and control
10. RJ45 Ethernet connection, with PoE
11. DC12V power with locking screw (connect the supplied DC PSU)
12. Power ON/OFF
13. Fall protection eye

## System Select Switch

	0	1080p60	8	720p30
	1	1080p50	9	720p25
	2	1080i60	A	1080p59.94
	3	1080i50	B	1080i59.94
	4	720p60	C	720p59.94
	5	720p50	D	1080p29.97
	6	1080p30	E	720p29.97
	7	1080p25	F	Via OSD/Webgui

### CAUTION:

- After changing the switch, you need to restart the camera to take effect.
- 720p30, 720p29.97 and 720p25 not supported by the SDI output.
- There are four ways to select the video output (via OSD, direct button combination on the remote control, via the webgui or via the rotary dial) of the camera, but the rotary dial takes priority after a reboot, except on setting F where all the outputs are defined digitally

### Power adapter

This product is equipped with a 12V/2A DC power supply. Insert the power supply according to the requirements, turn on the power switch. Alternatively use a PoE ethernet connection, the Power switch on the back of the camera needs to be switched to the 'ON' position.

### Power On

Pan-Tilt will rotate to the maximum position of top right after the camera started, then it returns to the center, the process of initialization is finished. The camera will show its current IR-channel setting and IP Address on the osd (Note: If the position preset 0 has been stored, the position preset 0 will be called after initialization). From this point onwards the user can control the camera with RC, Serial, USB or IP Communication.

## RS232 Interface

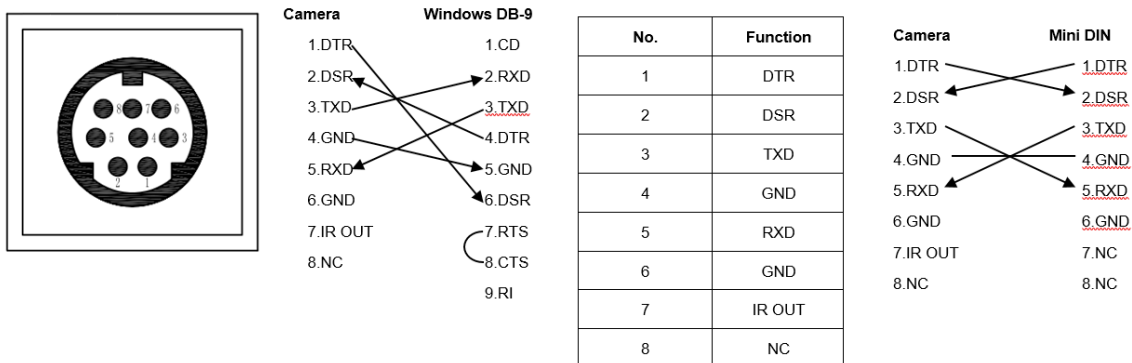

## RS232 network connection diagram

When connecting multiple cameras through RS-232, use daisy chaining network architecture. Max cable length for RS-232 is 10-15m.

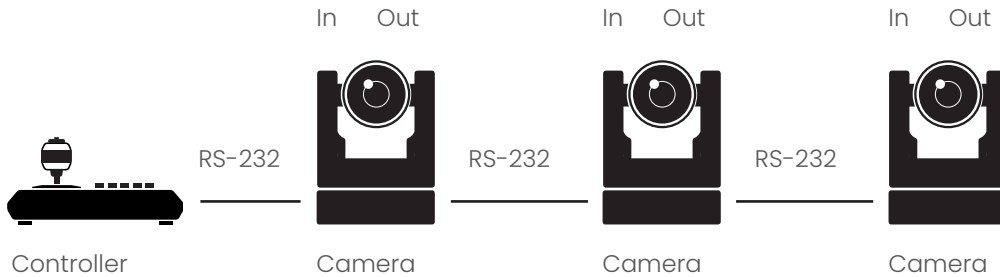

## RS485 network connection diagram

To connect multiple cameras by RS485, the cameras are attached to a 2-wire twisted pair bus (max length 1200m) that is terminated at both ends with a 120  $\Omega$  impedance resistor. The maximum distance from the bus to the camera or controller is 5m, when using only one camera, the impedance resistor is not needed.

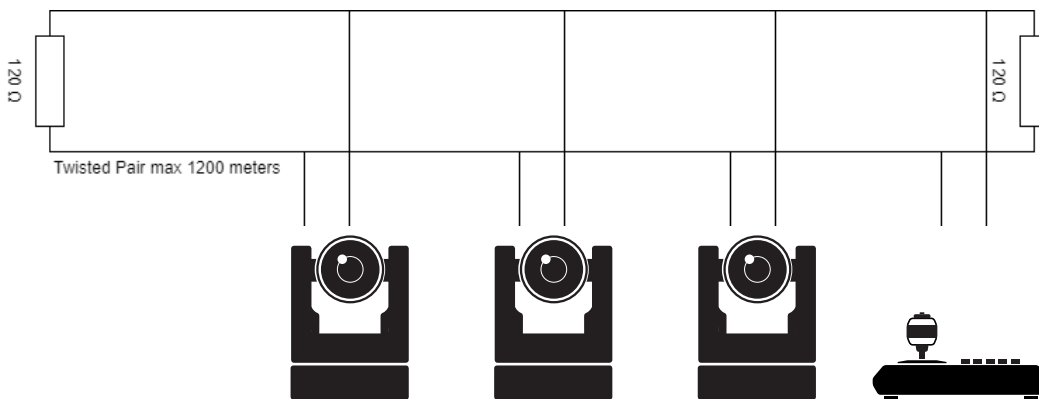

## IP network connection diagram

Connect an Avonic PoE camera to a LAN using a standard (PoE) switch, if the unit is simultaneously connected to both PoE and its own power supply, the power supply will take priority. If the power supply is disconnected when PoE is present, the camera will remain operational without interruption.

Addressing is done via IP, the Visca address in a Visca over IP environment is always 1.

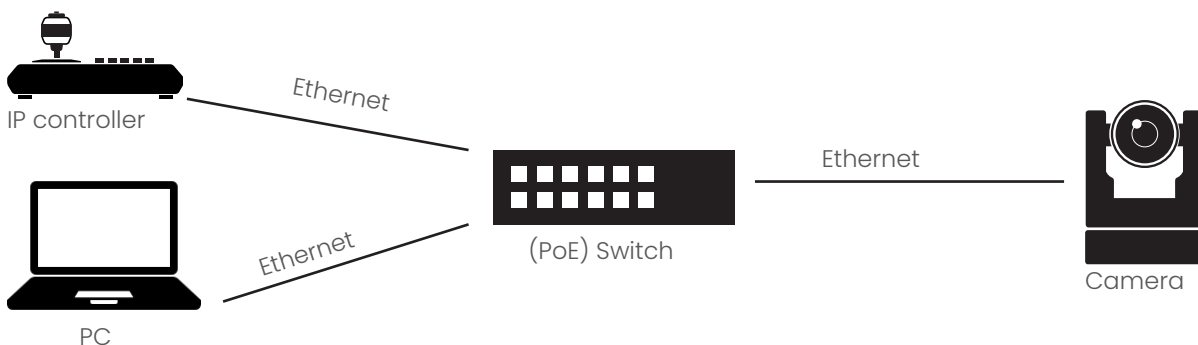

## Serial Communication Control

### COM port settings

In default working mode, the camera is able to connect to a VISCA controller with an RS-232 or RS-485 serial interface.

The camera can be controlled via RS-232, the parameters of RS-232 are as follows:

- Baud rate: 2400/4800/9600\*/115200
- Start bit: 1 bit.
- Data bit: 8 bits.
- Stop bit: 1 bit.
- Parity bit: none.

The camera can be controlled via RS-485, Half-duplex mode. The parameters are:

- Baud rate: 2400/4800/9600\*
- Start bit: 1 bit.
- Data bit: 8 bits.
- Stop bit: 1 bit.
- Parity bit: none.

For command list, see Appendix A

\* default value

## IP Control

### Network settings

By default the ip address of the camera is **192.168.5.163** with username and password **admin/admin**. Avonic IP cameras can be controlled by any device using the Visca over IP protocol (see command list Appendix A).

The control parameters for the CM4x and CM7x-IP cameras are as follows:

- IP Address: 192.168.5.163
- Username: admin
- Password: admin
- TCP or UDP port: 1259
- Parity bit: none.

# OPERATION

## Remote controller

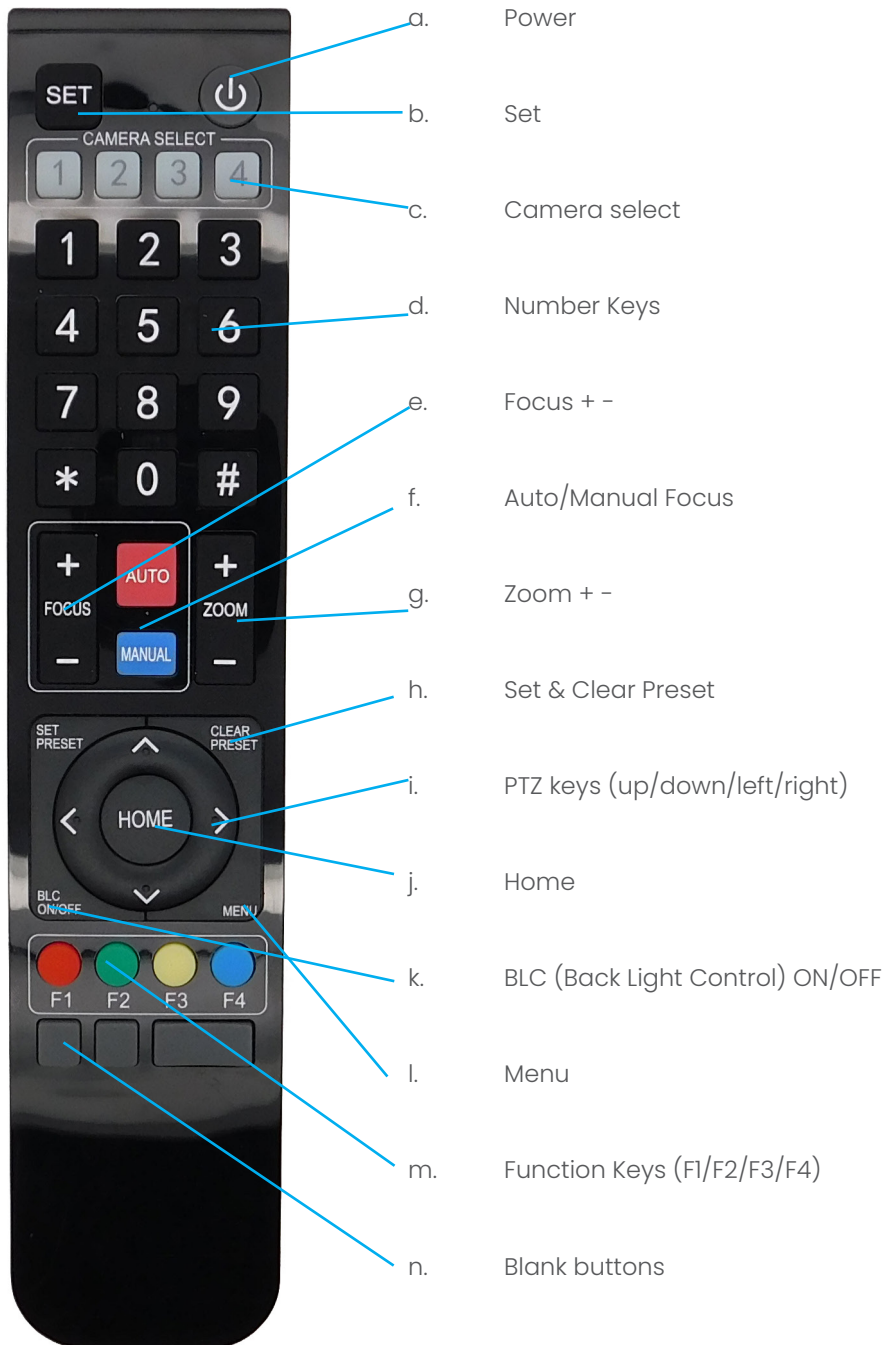

**a. Power**

Press the power button to turn on the camera. If the position preset 0 has been stored, the position preset 0 will be called after initialization. Press the power button again to turn the camera off, it will turn to the back when turned off, this is called the "privacy mode".

**b. Set**

This button has no function with this camera.

**c. Camera select**

Up to 4 different cameras can be controlled with 1 IR remote Control. With the camera select buttons [1,2,3,4] you can select the IR channel the remote control is using. The default camera IR channel is 1.

To control a camera on first use, please select camera 1 (IR channel 1) on the remote control. To control a second camera you first need to change the IR channel stored in the camera from 1 to 2.

- First turn off the other camera's in the room you don't want to change, to prevent that other camera's also get changed accidentally.
- Select camera 1 on the remote control, because the camera is still configured to listen to IR channel 1.
- Press [\*]+[#]+[F2] to change the IR channel inside the camera to IR channel 2. The camera will confirm this on screen.
- Select camera 2 on the remote control to control this camera.

Key Combinations: (Default IR address is 1)

[*]+[#]+[F1]	: Camera Address No. 1	[*]+[#]+[F3]	: Camera Address No. 3
[*]+[#]+[F2]	: Camera Address No. 2	[*]+[#]+[F4]	: Camera Address No. 4

**d. Number Keys**

The number keys are used to call presets. Press the number [0-9] of the preset desired and the camera will respond accordingly (See 'h' on how to set & clear presets)

**e. Focus + -**

Push the button [manual focus] first before using the focus buttons. Focus the camera with the [+] and [-] button. If the camera does not respond check if the camera is set to auto-focus.

**f. Auto/Manual Focus**

Set the camera in auto-focus or manual-focus. If the camera is configured to auto-focus the buttons [Focus + -] are disabled. When the camera is in "manual focus" modus and the Zoom buttons are used, the camera automatically switces to auto-focus.

**g. Zoom + -**

Zoom the camera with these buttons. When the camera is in "manual focus" modus and the Zoom buttons are used, the camera automatically switches to auto-focus.

**h. Set & Clear Preset**

A preset is a specific position of a camera that you save into the camera. A preset is assigned to a number from 0-9. To set a preset first point the camera in a specific directing and a specific zoom position. Now assign the position to a number with the button "Set Preset". You can call the preset by pressing the number 0-9 on the remote control.

Set Preset:	[SET PRESET]+[<number>]
Call Preset:	[<number>]
Clear Preset:	[CLEAR PRESET]+[<number>]

If the position preset 0 has been stored, this position will be called after initialization.

**i. PTZ keys (up/down/left/right)**

Move the camera in a direction.

**j. Home**

Set the direction of the camera to a center position.

**k. BLC (Back Light Control) ON/OFF**

Change the Back light control setting.

**l. Menu**

The Menu button opens the "On Screen Display (OSD)" menu. This menu is visible on the HDMI/SDI/IP output. If the menu is not in English, please press [\*]+[#]+[4] to change the Menu language to English.

**m. Function Keys (F1/F2/F3/F4)**

Used to configure the IR channel of the camera. See [c. Camera select] above for instructions.

**n. Blank buttons**

These buttons have no function with this camera.

## Other Key Combinations

[*]+[#]+[4]	: Menu set to English
[*]+[#]+[6]	: Restore factory defaults
[*]+[#]+[9]	: Flip switch (just temporary flip to view the image flipped)
[*]+[#]+[Auto]	: Enter into the aging mode, only for quality control purposes
[*]+[#]+[Manual]	: Restore the default username, password, and IP address

[#]+[#]+[#]	: Clear all presets
[#]+[#]+[0]	: Switch the video format to 1080p60*
[#]+[#]+[1]	: Switch the video format to 1080p50*
[#]+[#]+[2]	: Switch the video format to 1080i60*
[#]+[#]+[3]	: Switch the video format to 1080i50*
[#]+[#]+[4]	: Switch the video format to 720p60*
[#]+[#]+[5]	: Switch the video format to 720p50*
[#]+[#]+[6]	: Switch the video format to 1080p30*
[#]+[#]+[7]	: Switch the video format to 1080p25*
[#]+[#]+[8]	: Switch the video format to 720p30*
[#]+[#]+[9]	: Switch the video format to 720p25*

**\*NOTE: THE CAMERA RETURNS TO THE VIDEO OUTPUT SETTING OF THE ROTARY DIAL AFTER A REBOOT**

# OSD MENU

The OSD menu can be accessed by the Remote Control or an Avonic PTZ controller. In the following pages, the navigating is described for using the IR Remote Control.

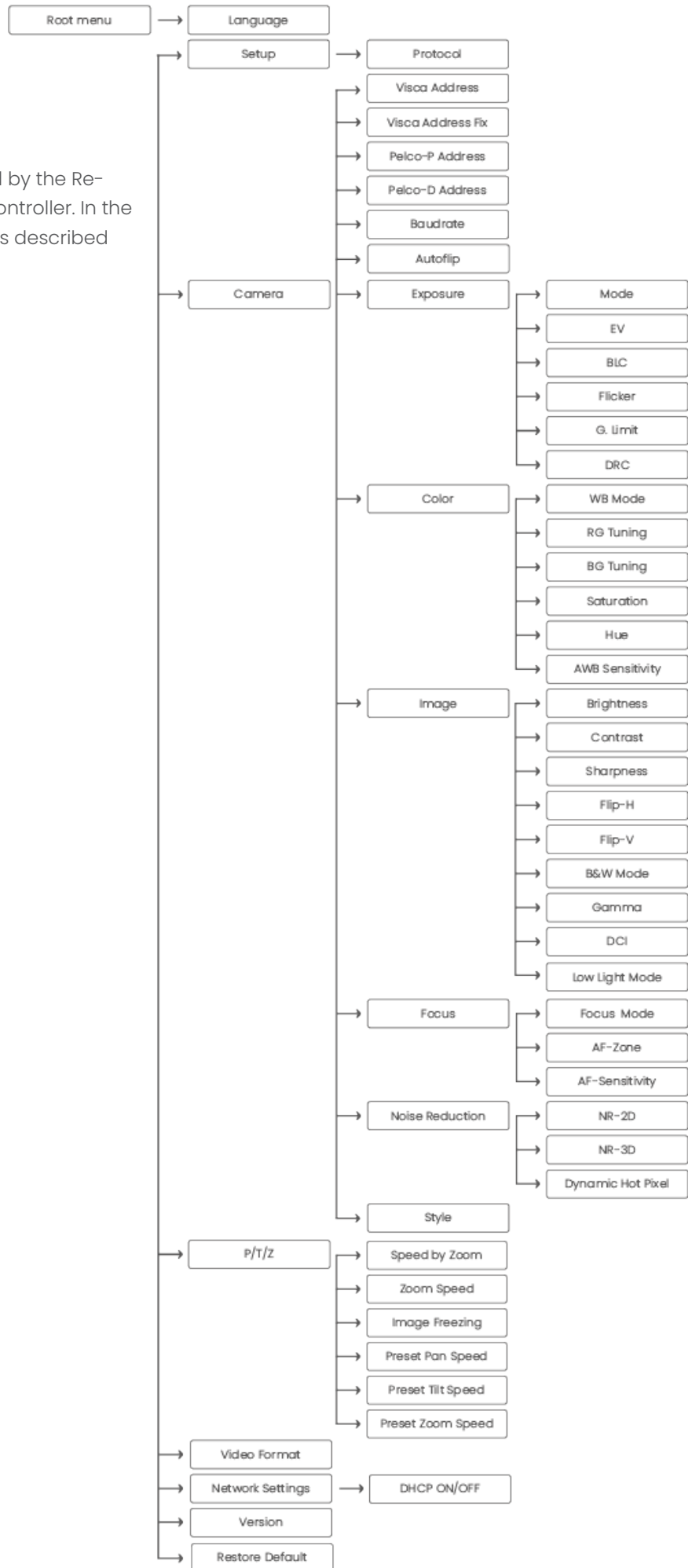



## 1. MENU

Press [MENU] button to display the main menu on the screen. Use the arrow buttons to move the cursor to the item to be set. Press the [HOME] button to enter the corresponding sub-menu. Press [◀▶] to change setting. Press [Menu] to go back

MENU	
▶	Language EN / CN
	Setup
	Camera
	P/T/Z
	Video Format
	Version
	Restore Default
▼▲	Select Item
◀▶	Change Value
[Home]	Enter
[Menu]	Exit

## 2. SETUP

SETUP	
▶	Protocol AUTO / VISCA / PELCO-D / PELCO-P
	Visca Address 1 ~ 7
	Visca Address Fix ON / OFF
	PELCO-P Address 1 ~ 255
	PELCO-D Address 1 ~ 255
	Baudrate 2400 / 4800 / 9600 / 38400 / 115200
	Autoflip ON / OFF
▼▲	Select Item
◀▶	Change Value
[Menu]	Back

## 3. CAMERA

CAMERA	
▶	Exposure
	Color
	Image
	Focus
	Noise Reduction
	Style Soft / Default / Normal / Clarity / Bright
▼▲	Select Item
◀▶	Change Value
[Menu]	Back

### 3.1 EXPOSURE

EXPOSURE	
▶	Mode Auto / Manual / SAE / AAE / Bright
	Iris F11 ~ F1.8 / CLOSE
	Shutter 1/25 ~ 1/10000
	EV ON / OFF
	EV Level -7 ~ +7
	BLC ON / OFF
	Flicker 50Hz / 60Hz / OFF
	G. Limit 0 ~ 15
	DRC 1 ~ 8 / CLOSE
▼▲	Select Item
◀▶	Change Value
[Menu]	Back

### 3.2 COLOR

COLOR	
▶	WB Mode Auto / 2400K ~ 7100K 100K increments / Manual / OnePush
	RG Tuning -10 ~ 10
	BG Tuning -10 ~ 10
	RG 0 ~ 255
	BG 0 ~ 255
	Saturation 60% - 200%
	Hue 0 ~ 14
	AWB Sensitivity Low / Middle / High
▼▲	Select Item
◀▶	Change Value
[Menu]	Back

### 3.3 IMAGE

The Flip function can be set, although the camera has an automatically flip function.

IMAGE		
▶	Brightness	0 ~ 14
	Contrast	0 ~ 14
	Sharpness	0 ~ 15
	Flip-H	ON / OFF
	Flip-V	ON / OFF
	B&W-Mode	Color / B&W
	Gamma	0.45 / 0.50 / 0.55 / 0.63 / Default
	DCI	1 ~ 8 / Close
	Low Light Mode	ON / OFF
▼▲	Select Item	
◀▶	Change Value	
[Menu] Back		

### 3.4 FOCUS

FOCUS		
▶	Focus Mode	Auto / Manual / OnePush
	AF-Zone	Top / Center / Bottom / All
	AF-Sensitivity	Low / Middle / High
▼▲	Select Item	
◀▶	Change Value	
[Menu] Back		

### 3.5 NOISE REDUCTION

NOISE REDUCTION		
▶	NR-2D	1 ~ 7 / Auto / OFF
	NR-3D	1 ~ 8 / Auto / OFF
	Dynamic Hot Pixel	1 ~ 5 / OFF
▼▲	Select Item	
◀▶	Change Value	
[Menu] Back		

### 3.6 STYLE

STYLE		
▶	Style	Default / Normal / Clarity / Bright / Soft
▼▲	Select Item	
◀▶	Change Value	
[Menu] Back		

#### 4. PTZ

PTZ		
▶	Speed by Zoom	ON / OFF
	Zoom Speed	1 ~ 8
	Image Freezing	ON / OFF
	Preset Pan Speed	1 - 25
	Preset Tilt Speed	1 - 21
	Preset Zoom Speed	1 - 8
▼▲	Select Item	
◀▶	Change Value	
[Menu]	Back	

#### 5. VIDEO FORMAT

VIDEO FORMAT		
▶	Video Format	1080p60/ 1080p50/ 1080i60/ 1080i50/ 1080p30/ 1080p25/ 720p60/720p50/ 720p30/ 720p25/ 1080p59.94/ 1080i59.94/ 1080p29.97/720p59.94/ 720p29.97
▼▲	Select Item	
◀▶	Change Value	
[Menu]	Back	

#### 6. NETWORK SETTINGS

▶	DHCP	ON/OFF
	IP Address	xxx.xxx.xxx.xxx
[Menu]	Back	

#### 7. VERSION

VERSION			
▶	MCU Version	nr	date
	Camera Version	nr	date
	AF Version	nr	date
[Menu]	Back		

#### 8. RESTORE DEFAULT

RESTORE DEFAULT		
▶	Restore default?	NO / YES
▼▲	Select Item	
◀▶	Change Value	
[Menu]	Back	
[Home]	OK	

# WEBGUI

## Login

default IP\*: **192.168.5.163**  
default username: **admin**  
default password: **admin**

The login screen:

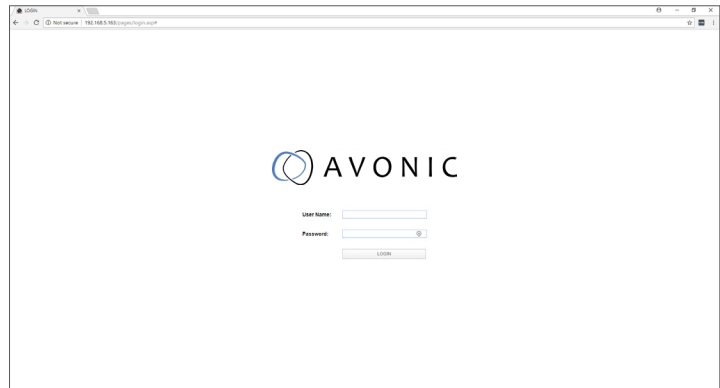

### \*Note:

If DHCP is enabled and there is no DHCP server available, the camera will self appoint an IPv4 link-local address between 169.254.0.0 and 169.254.255.255. The IP address is shown on screen at start-up.

## Local

A preview of the camera ip-video output.

On the right is PTZ control, speed by zoom slider, focus and zoom functionality.

Click on the camera icon below the screen to switch preview between main stream and sub stream. Note that preview only works when the main- or sub-stream is set to H264 (see page 22).

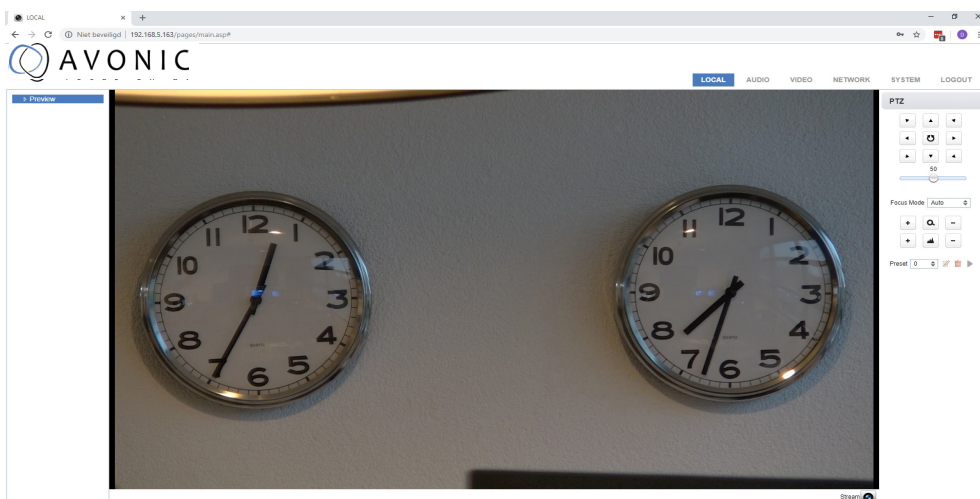

## Audio

Enable or disable embedding of the audio input on the back of the camera.

Select encoding type mp3, AAC or G.711A

Select sample rate: 16000, 32000, 44100, 48000

Sample bits: always 16

Bitrate Kbps : 32, 48, 64, 96, 128

Channel: Mono or Stereo

Input volume: 1 ~ 10

Audio Delay (ms) 0 ~ 200



LOCAL **AUDIO** VIDEO NETWORK SYSTEM LOGOUT

> AUDIO

**Audio**

Enable

Encode Type

Sample Rate

Sample Bits

Bit Rate

Channel

Input Volume  2

Audio Delay(ms)  0

SAVE

## Video

In this section you will find the various settings concerning the video output, including the main settings as found in the normal OSD menu of the camera..

### Video Encoder

#### Video Encoder options:

	Main Stream	Sub Stream
Compressed Format :	MJPEG/ H.264/ H265	MJPEG/ H.264/ H265
Profile:	BP/ MP/ HP	BP/ MP/ HP
Image Size:	1920*1080/ 1280*720	1920*1080/ 1280*720/ 320*180/ 320*240/ 640*360
Rate Control:	CBR (constant bit rate)/ VBR (variable bit rate) depending on format	
Image quality:	fixed at 'best'	fixed at 'good'
Bit Rate (Kb/S):	64-40960	64-40960
Frame Rate (F/S):	5-60 frames per second	5-30 frames per second
I Frame Interval:	1-300	1-150
I Frame min. QP:	10-51	10-51
Stream name:	live/av0	live/av1
<b>RTSP Link:</b>	<b>rtsp://&lt;ip-address&gt;/live/Av0</b>	<b>rtsp://&lt;ip-address&gt;/live/av1</b>
RTP Package*	Small Package (standard MTU size, 1500 bytes) Big Package (approx. 60kb MTU size)	

Click on 'Save' to apply settings, a small dialogue screen appears in the bottom right of the window telling the settings are saved successfully.

\* NOTE: a reboot is required after changing this setting.

## Streaming Video

### Stream options:

	Main Stream	Sub Stream
Enable:	mark checkbox to enable/ disable	mark checkbox to enable/ disable
Protocol type:	RTMP, SRT	RTMP, SRT
Host Address:	192.168.5.11	192.168.5.11
Host port:	1935	1935
Stream name:	live/av0	live/av1
User Name:	empty is default setting	empty is default setting
Password:	empty is default setting	empty is default setting
SRT Password for stream encr.:	empty is default setting	empty is default setting
Crypto key lenght in bytes:	0, 16, 24, 32	0, 16, 24, 32

Click on 'Save' to apply settings, a small dialogue screen appears in the bottom right of the window telling the settings are saved successfully

## Multicast Streaming

### Stream options:

	Main Stream	Sub Stream
Enable:	mark checkbox to enable/ disable	mark checkbox to enable/ disable
Protocol type:	RTP/ TS Multicast/ TS Unicast	RTP/ TS Multicast/ TS Unicast
Address (multicast):	224.0.0.0~ 239.255.255.255	224.0.0.0~ 239.255.255.255
Address (unicast):	Specify the ip address to which you want the Unicast stream pushed	
Port:	4000 (default)	4002 (default)
Acces Method:	rtp://224.1.2.3:4000	rtp://224.1.2.3:4002

Click on 'Save' to apply settings, a small dialogue screen appears in the bottom right of the window telling the settings are saved successfully.



## Camera Settings and explanation

In this area all OSD settings can be changed like when using the remote control:

Focus, Exposure, Color, Image, Noise Reduction, Style. If a value is changed with the remote control, use the [refresh] button to update the webgui.

Note that only a picture will be shown with the main video stream set to H264.

- ▶ Video Encoder
- ▶ Streaming Video
- ▶ Multicast streaming
- ▶ **Camera settings**
- ▶ OSD
- ▶ Output format

### Camera settings



Focus	Exposure	Color	Image	NR	Style	REFRESH
WB Mode	Auto					↕
RG Tuning						0
BG Tuning						0
Saturation	100%					↕
Hue						7
AWB Sensitivity	High					↕

\*Click the "Refresh" button to refresh parameter.

\*Effective after changed parameters

## Focus

### Focus mode:

Auto – the camera determines the focus position by itself and will adjust to the contents of the filmed object.

Manual – the user is able to set a fixed focus position manually. This can be useful when the contents of the filmed object are not clear towards the background and the autofocus has difficulty finding the correct focusing.

One-push – the camera will focus once and keep the focus in that position until another command to focus again is sent.

### AF-Zone:

This setting defines the area where the autofocus is aimed at.

### AF-sensitivity:

Sets the level of speed with which the autofocus responds. This can be useful if you have people walking through the picture, if the setting is on 'High' the camera will respond immediately while at 'Low' or 'Medium' the camera will not react to sudden, short changes in the picture.

- ▶ Video Encoder
- ▶ Streaming Video
- ▶ Multicast Streaming
- ▶ **Camera Settings**
- ▶ OSD
- ▶ Output Format
- ▶ SRT

### Camera settings



Focus	Exposure	Color	Image	NR	Style	CCM	REFRESH
Focus Mode	Auto						↕
AF-Zone	Center						↕
AF-Sensitivity	Low						↕

\*Click the "Refresh" button to refresh parameter.

\*Effective after changed parameters

## Exposure

If you click in the field after the option 'mode', you will see that you have the following options: Auto, Manual, SAE, AAE and Bright.

### Mode: auto

The camera determines the iris and shutter settings. There are a couple of settings to present the camera with some limits as to what it may do to the image:

### EV

on/off and level

EV is Exposure Value, to set this value is to create a quick adjustment to your current exposure settings if the light conditions require this without actually changing the fundamental values like iris and shutter. Remember that this is a software setting, take care to not 'overdo' the settings or the picture will become washed out bright or too dark to make out details in shadows.

### BLC

Back Light Compensation ON/OFF

This setting is to compensate for having to film against bright lighting directly into the lens.

See the pictures below:

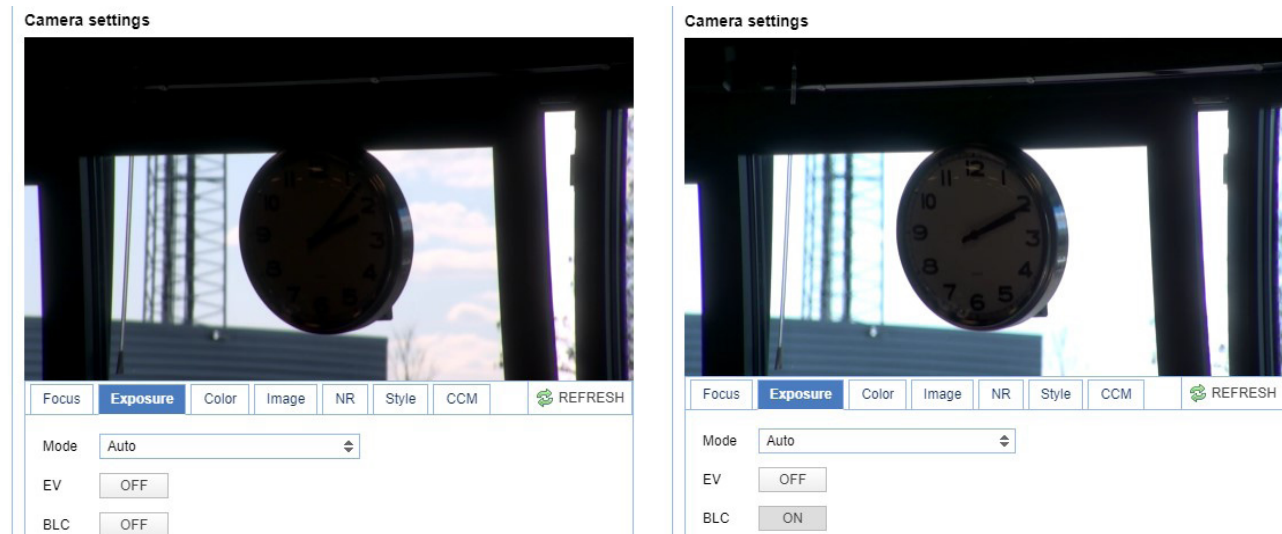

### Flicker

This setting is to set your camera up in such a way that it's able to cope with the flickering of artificial lighting in the space where it has to operate. The options are 50Hz, 60Hz and off.

### G.Limit

Gain limit is the maximum level of artificial brightness and contrast that the camera may add to the image automatically. This setting will make a significant difference to the overall picture. Make sure that this setting is kept 'within reason' as it can add noise to the picture in dark areas and produce a washed out greyish picture.

### DRC

Dynamic Range Compression has a similar effect on the picture as the above mentioned gain limit. The DRC works by compressing the natural dynamic range of the image by taking out the darkest and lightest parts of the image. This can be a particular helpful setting when the light conditions are challenging. The differences should be clearly visible in dark parts of the image, they will become lighter/more grey once the level of DRC is increased.

## Manual Mode

In this mode you can set manually the shutter, Iris and DRC options.

### Shutter

The first setting to make is the shutter setting, this determines the amount of time per second that the sensor is exposed. The shutter speed setting range is 1/25th of a second (40 milliseconds) to 1/10000th of a second (0.1 milliseconds)

You can imagine that when you shoot video with a shutter time of 1/25th of a second, the video becomes blurry and overexposed. The faster the shutter is set to open and close, the sharper your filmed object will become, but the amount of light that falls onto the sensor is also diminished. If you don't know exactly what you are doing or the light conditions change a lot, it's best practice to keep the camera on the automatic exposure setting.

### Iris,

The iris is a tool in a lens that regulates the amount of light that passes through the lens and onto the sensor by altering the diameter of the hole that the light is entering through. The diameter of the hole is measured in F-stop value. A higher value lets in less light while a lower setting lets in more light.

The iris setting affects the length of the depth of field. The higher F-stop you use the deeper your depth of field – and vice versa. This is because the smaller the aperture, the more focused the light beams will be, resulting in a more focused image.

### DRC

Dynamic Range Compression has a similar effect on the picture as the above mentioned gain limit. The DRC works by compressing the natural dynamic range of the image by taking out the darkest and lightest parts of the image. This can be a particularly helpful setting when the light conditions are challenging. The differences should be clearly visible in dark parts of the image, they will become lighter/more grey once the level of DRC is increased.

Focus	Exposure	Color	Image	NR	Style	CCM	REFRESH
Mode	Manual						
Shutter	1/100						
Iris	F1.8						
DRC	7						

\*Click the "Refresh" button to refresh parameter.

\*Effective after changed parameters

### SAE Mode, Shutter Auto Exposure

In this mode the shutter speed is user adjustable, the camera itself decides the best iris F-stop value for an optimal exposure setting.

Keep in mind that the shutter speed is the amount of time that each frame of the sensor has been exposed to light.

To compensate for poor lighting conditions, it is possible to adjust the DRC or Dynamic Range Compression. The DRC works by compressing the natural dynamic range of the image by taking out the darkest and lightest parts of the image. This can be a particular helpful setting when the light conditions are challenging. The differences should be clearly visible in dark parts of the image, they will become lighter/more grey once the level of DRC is increased.

### AAE Mode, Aperture Auto Exposure

The camera will automatically set the shutter speed based on the iris F-stop value (aperture) set by the user. As the camera determines the preferable shutterspeed it is possible in this mode to turn the antiflicker setting to the required 50Hz or 60Hz to eliminate the effects of a shutter functioning at 1/50th of a second for example.

In this mode, both the Gain limit and DRC are available to compensate for challenging light conditions.

### Bright mode

This mode is to try and create a decent image when the light conditions are exceptionally poor. In this mode keep the Bright level, Gain limit and DRC as low as possibly acceptable to avoid getting too much noise in the picture. If the level of noise in the image becomes unacceptable, noise reduction is available to smooth the picture over.. (See page 31)

Focus	Exposure	Color	Image	NR	Style	CCM	REFRESH
Mode	Bright						
Bright							6
Flicker	50Hz						
G.Limit							4
DRC	7						

\*Click the "Refresh" button to refresh parameter.

\*Effective after changed parameters

## Color

The color modes inside the camera are designed in such a way that the video output of the camera can match the current light conditions to produce accurate colors. There are several automatic preset modes and a manual mode to set the colors to the preference of the user.

### WB mode auto

The camera continuously measures and defines the light conditions and acts accordingly. In this mode there are some adjustments that can be made to tune the image to the preference of the user.

### RG Tuning

Red Gain Tuning, increase or decrease red

### BG Tuning

Blue Gain Tuning, increase or decrease blue

### Saturation

How saturated the image's colors are. 0% would produce a black and white image.

### Hue or tint

The balance between green and red. 0 is green, 14 is red.

### AWB or Auto White Balance Sensitivity

how quickly the camera responds to changing light settings.

- ▶ Video Encoder
- ▶ Streaming Video
- ▶ Multicast streaming
- ▶ **Camera settings**
- ▶ OSD
- ▶ Output format

#### Camera settings



Focus	Exposure	Color	Image	NR	Style	REFRESH
WB Mode	Auto					
RG Tuning						0
BG Tuning						0
Saturation	100%					
Hue						7
AWB Sensitivity	High					

\*Click the "Refresh" button to refresh parameter.

\*Effective after changed parameters

## Image

The image section of the camera consists of settings that have an effect on the image post-processing, basically these settings are all artificial, they don't affect the optical parts of the camera itself.

### Brightness

The amount of detail that is visible in darker areas of the image. Be careful not to set this setting too high as you will see that the image becomes 'milky-white'.

### Contrast

The amount of detail that is visible in lighter areas of the image.

### Sharpness

Artificial contrast, be careful no to set this too high as it will create a sort of halo around sharp edges of filmed objects. The setting of sharpness coincides with the setting of noise reduction.

### Gamma

The gamma curve selection has to do with the perception of the human eye to lighter and darker. If you select a higher rate of gamma, you will see that the picture become darker, but you get also more detail.

### DCI

The Dynamic Contrast affects the contrast of the picture. The higher the number, the more contrast you will get.

### B&W Mode

Black and White Mode makes the picture black and white.

### Flip-H, Flip-V, Auto flip

The Flip-H mode turns the picture horizontally, while the Flip-V mode turns it vertical by 180 degrees. When Auto Flip is on, the camera will automatically flip the picture horizontal and vertical.

### Low-Light Mode

The Low-Light mode is present to be able to film when the environment in which the camera sits is almost completely dark. The framerate will drop to 10 frames per second to catch as much light on the sensor as possible. If this mode is needed to produce a picture, add more light to the scene to get better results.

Focus	Exposure	Color	Image	NR	Style	CCM	REFRESH
Bright			<input type="range" value="6"/>				
Contrast			<input type="range" value="8"/>				
Sharpness			<input type="range" value="6"/>				
Gamma			<input type="text" value="0.45"/>				
DCI			<input type="text" value="OFF"/>				
B&W Mode			<input type="text" value="Color"/>				
Flip-H			<input type="text" value="OFF"/>				
Flip-V			<input type="text" value="OFF"/>				
Auto Flip			<input type="text" value="OFF"/>				
Low-Light Mode			<input type="text" value="OFF"/>				

\*Click the "Refresh" button to refresh parameter.

\*Effective after changed parameters

## NR - Noise Reduction

Noise reduction can be used to soften the image when noise is present due to poor lighting conditions. The higher the amount of noise reduction, the softer the image will get, ultimately losing details. Be careful when adjusting the noise reduction, it can take away the natural 'crispness' of the image. Better practice is to add light to the filmed object to avoid having your dynamic contrast and gain set too high, causing noise in the first place.

### NR-2D

Is used for still standing objects.

### NR-3D

is used for moving objects.

## Dynamic Hot Pixel

A dynamic hot pixel is a defective pixel which look much brighter than they should and will sometimes become visible due to long exposure shots of the camera at a higher rate of light sensitivity. This is often visible as sparkles in the picture. The Dynamic Hot Pixels mode corrects the pixel so that the pixel will appear as normal on the filmed picture.

- ▶ Video Encoder
- ▶ Streaming Video
- ▶ Multicast Streaming
- ▶ **Camera Settings**
- ▶ OSD
- ▶ Output Format
- ▶ SRT

**Camera settings**



Focus	Exposure	Color	Image	<b>NR</b>	Style	CCM	REFRESH
				NR-2D: 5			
				NR-3D: 5			
				Dynamic Hot Pixel: OFF			

\*Click the "Refresh" button to refresh parameter.  
\*Effective after changed parameters

## Style

### Style

Here you can choose the style you want, such as default (standard setting), normal (which makes the picture more 'natural'), clarity (makes the picture more clear), bright (which makes the picture more bright) and soft (softens the picture).

Focus	Exposure	Color	Image	NR	<b>Style</b>	CCM	REFRESH
					Style: Clarity		

- Default
- Normal
- Clarity**
- Bright
- Soft

\*Click the  
\*Effective



### CCM Customizable Color Matrix

If the additional license for SRT and the Customizable Color Matrix (CCM) has been purchased, the Camera Settings menu will have an extra tab in the camera settings; CCM. The CCM is intended to finetune the color settings of the camera to seamlessly integrate with an existing camerasystem.



- ▶ Video Encoder
- ▶ Streaming Video
- ▶ Multicast Streaming
- ▶ **Camera Settings**
- ▶ OSD
- ▶ Output Format
- ▶ SRT

#### Camera settings



	Focus	Exposure	Color	Image	NR	Style	CCM	REFRESH
Enable CCM <input checked="" type="checkbox"/>								
			R	G	B		CCM	
R			406	32921	15		268	
G			32824	367	32823		256	
B			5	32988	470		255	

\*Click the "Refresh" button to refresh parameter.

\*Effective after changed parameters

## OSD

Note that only the output of the camera will be shown with the main stream set to H264.

In this area it is possible to put a camera name and time as overlay on the ip-stream (Overlay is exclusively available on the ip-stream, not on the other outputs).

Show time and show title can be enabled or disabled by marking or unmarking the checkbox next to the respective setting (the time and name settings can be found under the tab System chapters Attributes and Time).

Below is a dropdown menu for the desired font color as well as directional arrows to move the title and time to the preferred position on the screen.

### OSD Font Size (related to Camera name and Time)

Scale size automatically to resolution for both main- and substream, check or uncheck box, if checked the camera name and time overlay will always scale with the image, keeping the proportions intact.

Save to apply settings, a small dialogue screen appears in the bottom right of the window telling the settings are saved successfully

▶ Video Encoder  
▶ Streaming Video  
▶ Multicast streaming  
▶ Camera settings  
▶ **OSD**  
▶ Output format

### OSD

CAMERA-1  
01/01/1970 00:16:03

Show Time       OSD Offset  Title  Time

Show Title

Time Font Color

Title Font Color

SAVE

### OSD Font Size

According to the resolution

Scale size automatically

Master Stream OSD Font Size

Slave Stream OSD Font Size

SAVE

## Output Format

This setting is related to the output resolution and framerate on the HDMI and SDI connectors, to set the resolution of the main- and sub-IP streams use the webgui. The resolution of the USB output is determined by the computer connected to it.

Save to apply settings, a small dialogue screen appears in the bottom right of the window telling the settings are saved successfully

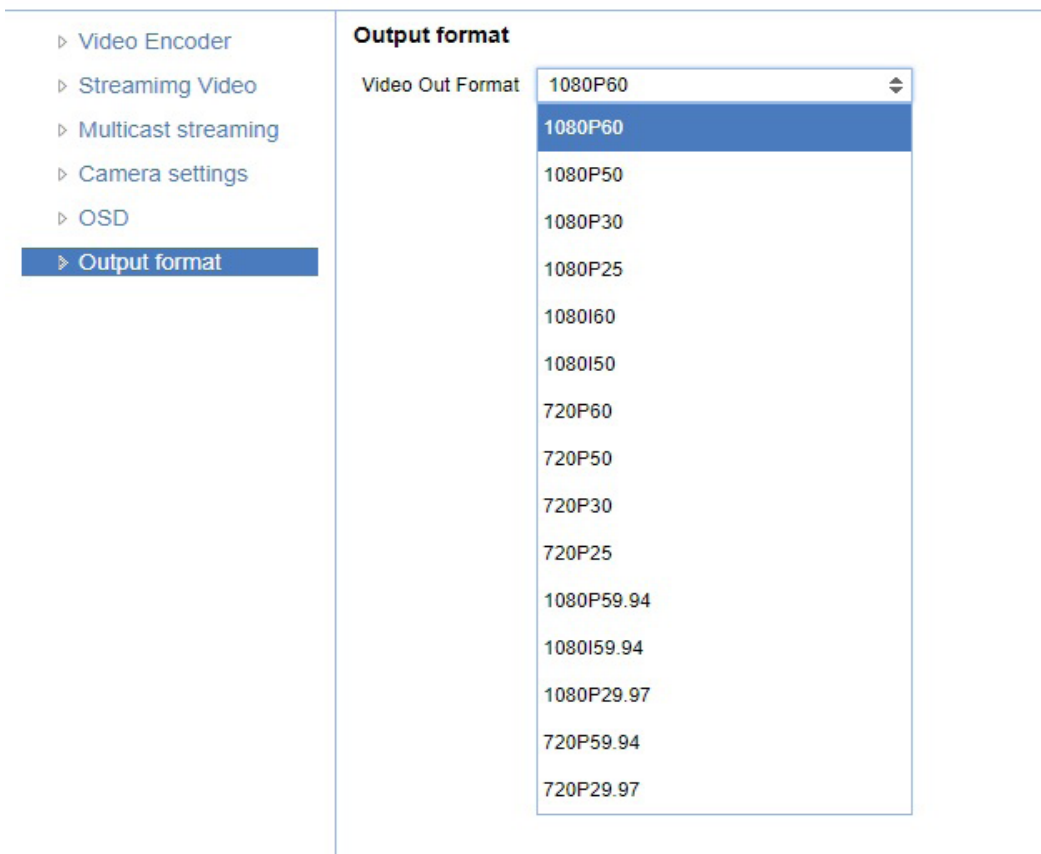

The screenshot displays a web interface with a sidebar on the left and a main content area on the right. The sidebar contains a list of menu items: 'Video Encoder', 'Streaming Video', 'Multicast streaming', 'Camera settings', 'OSD', and 'Output format'. The 'Output format' item is highlighted with a blue background. The main content area is titled 'Output format' and features a dropdown menu labeled 'Video Out Format'. The dropdown menu is open, showing a list of video resolution and frame rate options: 1080P60, 1080P50, 1080P30, 1080P25, 1080I60, 1080I50, 720P60, 720P50, 720P30, 720P25, 1080P59.94, 1080I59.94, 1080P29.97, 720P59.94, and 720P29.97. The '1080P60' option is currently selected and highlighted in blue.

## SRT Settings

These settings are related to the SRT streaming protocol; the port, passkey and encryption bit can be defined. SRT Caller mode and Listener mode are supported.

**When not using Encryption, please make sure to set the crypto length to 0**

### Listener mode settings



<ul style="list-style-type: none"><li>▶ Video Encoder</li><li>▶ Streaming Video</li><li>▶ Multicast Streaming</li><li>▶ Camera Settings</li><li>▶ OSD</li><li>▶ Output Format</li><li><b>▶ SRT</b></li></ul>	<h4>SRT</h4> <p>Port SRT <input type="text" value="9000"/></p> <p>Password for stream encryption <input type="password"/></p> <p>Crypto key length in bytes <input type="text" value="0"/></p> <p><input type="button" value="SAVE"/></p>
--	---

### Caller mode settings



<ul style="list-style-type: none"><li>▶ Video Encoder</li><li><b>▶ Streaming Video</b></li><li>▶ Multicast Streaming</li><li>▶ Camera Settings</li><li>▶ OSD</li><li>▶ Output Format</li><li>▶ SRT</li></ul>	<h4>Streaming Video</h4> <p>Stream <span style="float: right;">Main Stream</span></p> <p>Enable <input type="checkbox"/></p> <p>Protocol Type <input type="text" value="SRT"/></p> <p>Host Address <input type="text" value="192.168.5.11"/></p> <p>Host Port <input type="text" value="1935"/></p> <p>Stream Name <input type="text" value="live/av0"/></p> <p>User Name <input type="text"/></p> <p>Password <input type="password"/></p> <p>Password for stream encryption <input type="password"/></p> <p>Crypto key length in bytes <input type="text" value="0"/></p> <p><input type="button" value="SAVE"/></p>
--	--

# Network

## Port Settings

On this page specific ports can be defined for the different streaming outputs and protocols the camera supports. Make sure these settings don't interfere with other uses and services on the same network. Save to apply settings, a small dialogue screen appears in the bottom right of the window telling the settings are saved successfully.

Port Name	Value
Port Data	3000
Port Web	80
Port Onvif	2000
Port Soap	1936
Port RTMP	1935
Port Rtsp	554
Port Visca	1259

## Ethernet

### Ethernet and DNS settings

In this section the IP-settings for the ethernet adapter can be made; DHCP, IP address, Subnet Mask, Default Gateway and on the next tab, the Preferred and Alternative DNS server can be specified.

The MAC Address can be found on the last visible line.

Save to apply settings, a small dialogue screen appears in the bottom right of the window telling the settings are saved successfully and that a reboot is needed for the changes to take effect.

Setting	Value
DHCP	<input type="checkbox"/>
IP Address	192.168.5.163
Subnet Mask	255.255.255.0
Default Gateway	0.0.0.0
MAC Address	98:14:D2:...

  

Setting	Value
Preferred DNS Server	0.0.0.0
Alternative DNS Server	0.0.0.0

## System

### License

If you have purchased the license for the premium features of this camera, this is where you can enter the License key to unlock them. No need for a reboot, it is instantly activated. The license can be bought through your local sales channel or contact Avonic directly.



▶ License

- ▶ Attributes
- ▶ Time
- ▶ User
- ▶ Update
- ▶ Default
- ▶ Reboot
- ▶ Serial Settings
- ▶ Import/Export Params
- ▶ PTZ Speed

**License**

License

SAVE

### Attributes

Specify a specific device name to display in the OSD, which can be useful when using multiple cameras on the same LAN. Device-ID is always 1 (addressing is done via IP). The language cannot be changed. Save to apply settings, a small dialogue screen appears in the bottom right of the window telling the settings are saved successfully.

WARNING: The ONVIF protocol doesn't accept spaces in the camera name.

▶ Attributes

- ▶ Time
- ▶ User
- ▶ Update
- ▶ Default
- ▶ Reboot

**Attributes**

Device Name

Device ID

Language

SAVE

### Time

Manually set time and date or synchronize time and date via a computer or an external server on the LAN or WAN.

- Attributes
- Time**
- User
- Update
- Default
- Reboot

#### Time

Date Format	MM-DD-YYYY
Date Sprtr	/
Zone	(GMT+01:00)Berlin, Stockholm, Rom
Hour Type	24 Hours
NTP Enable	<input type="checkbox"/>
Update Interval	1 day
Host Url	time.nist.gov
Host Port	123

SAVE

#### Time Settings

Time Settings	Synchronize with computer time
Computer Time	2019-02-21 14:10:47

SYNC.

### User

Define different users with levels of permission and different username passwords combinations. There are 2 levels of users: administrators with access to all features and user-1 and user-2 with access to the preview and PTZ-controls.

- Attributes
- Time
- User**
- Update
- Default
- Reboot

#### User

Authority	admin
User Name	admin
Password	.....
Confirm Password	

SAVE

### Update

By default this screen shows a readout of the current firmware versions. Update file provides a firmware upgrade functionality via this screen. When the camera is done uploading and processing the update it will reboot. Make sure to refresh your browser and log in again after the reboot.

- Attributes
- Time
- User
- Update**
- Default
- Reboot

#### Update

MCU Version	V2.4.1 2019-1-24
Camera Version	V2.4.1 2019-1-25
AF Version	V4.0.2 2018-12-4
Update File	Bestand kiezen Geen bestand gekozen

UPGRADE

### Default

Click on the button to perform a factory default. The camera will be ready for use again after the boot cycle.

- ▷ Attributes
- ▷ Time
- ▷ User
- ▷ Update
- ▷ Default**
- ▷ Reboot

**Default**  
This will restore the factory defaults

### Reboot

Click on the button to activate a reboot, the camera will be ready for use after it has restarted. Log in again after the reboot.

- ▷ Attributes
- ▷ Time
- ▷ User
- ▷ Update
- ▷ Default
- ▷ Reboot**

**Reboot**  
REBOOT

### Serial Settings

Choose the preferred protocol to use and the accompanying address to go with it. Or leave the system on 'auto' and have the camera detect which protocol is being used (addressing is still needed, even on auto).



- ▷ License
- ▷ Attributes
- ▷ Time
- ▷ User
- ▷ Update
- ▷ Default
- ▷ Reboot
- ▷ Serial Settings**
- ▷ Import/Export Params
- ▷ PTZ Speed

**Serial settings**  
Protocol Type:   
Visca Address:   
Visca Address Fix:   
PELCO-P Address:   
PELCO-D Address:   
Baudrate:



## Import/ Export Parameters

The CM7x cameras have the ability to import or export a configuration.

Note: This option does not include a preset!



## P/T/Z

- PTZ Speed:** It is possible to increase the maximum pan and tilt speed, this can be useful in a conference system where quick action is necessary. The camera will produce slightly more noise when this setting is set to 'high'.
- Speed by zoom:** This mode affects PTZ speed when the camera is zoomed in to its max. If you move the stick of your controller when this mode is unabled, it will move too fast to control it. Enabling reduces this speed.
- Image Freezing:** You can freeze the image when the camera moves from one preset to another preset when you use your (remote) controller.
- Low Power Mode:** When this mode is enabled, the camera will set your ethernet port off to reduce the power the camera uses.
- Zoom Speed:** You can set the speed to which the camera will zoom in to the image. The higher the number, the faster the camera will zoom in.
- Preset Pan, Tilt and Zoom Speed:** This mode affects the speed to which the camera is switching from one preset to another when you use your (remote) controller. The higher the number, the faster it will switch.

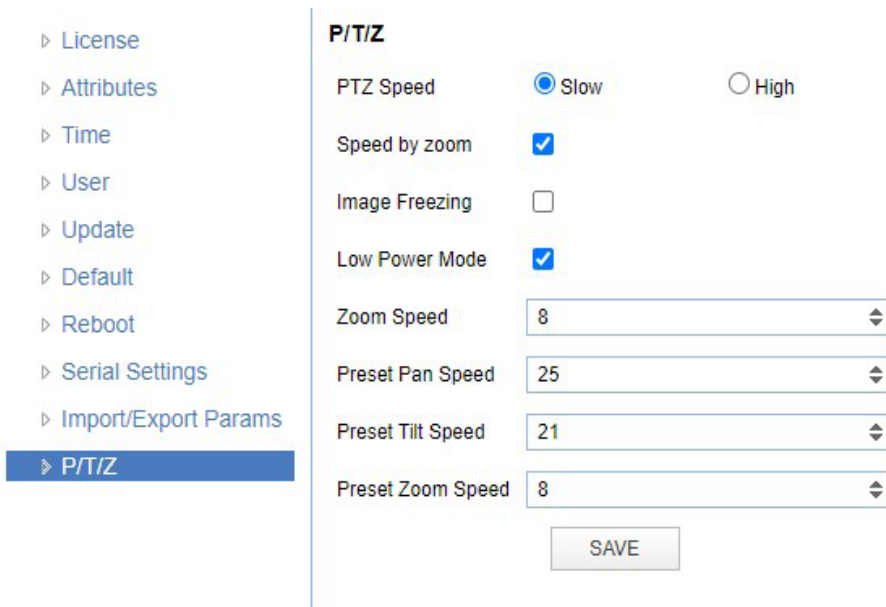

### MJPEG Snapshot

The Avonic CM7x-IP cameras are equipped with a MJPEG snapshot feature for example to implement into third party software.

To access the MJPEG snapshot feature use the following format:

`http://IP/img/capjpg/snapshot.jpg`

Every time the page is refreshed the picture will be updated.

# MAINTENANCE

---

## Camera Maintenance

- If the camera will not be used for a long time, please turn off the power switch, disconnect AC power cord of AC adaptor to the outlet.
- Use soft cloth or tissue to clean the camera cover.
- Please use the soft dry cloth to clean the lens. If the camera is very dirty, clean it with diluted neutral detergent. Do not use any type of solvents, which may damage the surface.

## Unauthorized Use

- Do not film extreme bright objects for a prolonged period of time, such as sunlight, light sources, etc.
- Do not operate in unstable lighting conditions, otherwise the produced image could be less than optimal.
- Do not operate close to powerful electromagnetic radiation, such as TV or radio transmitters, etc.

# TROUBLESHOOTING

---

## General Advice

- Turn the camera off and on again and check if the problem persists.
- Restore to Factory Default

## Power Issues

- No self-test (applies only to PTZ cameras) and no power LED
  - Check the net power
  - Check the power supply
  - Check the physical power button on the back of the camera

## Image

- No image
  - Check power of camera and monitor
  - Check video cable quality and length
  - Check if video specifications of monitor match the specs of the camera
  - Check if the iris under exposure settings is set to 'closed'
- Abnormal image
  - Check video cable quality and length
  - Check cable connections
- Dithering or flickering image
  - Check camera fixation and nearby vibration sources
  - Check anti-flickering setting in OSD
  - Check Noise Reduction settings in OSD
- Color issues
  - Check options in OSD, like exposure, white balance, color temp, Red and Blue tuning

## Control

- No self-test (PTZ cameras only) and no power LED
  - Check the net power
  - Check the power supply
- Remote Controller does not work
  - Check power of the controller
  - Check RS-232 or RS-485 cable quality, length, polarity and network architecture
  - Check serial communication settings on both camera and controller
  - Check VISCA / PELCO address settings on both camera and controller
  - Check IP network settings on both camera and controller

## WebGUI

- Cannot enter WebGUI
  - Check the network cable
  - Check if the computer is connected to the same subnet as the camera
  - use an incognito window in your browser, sometimes cache issues arise when using multiple cameras that have the same default IP address
  - Reset the factory default ip settings by pressing [\*] [#] [Manual] and Reboot
- Firmware update failed
  - Check firmware file integrity, download it again.
  - Make sure you are trying to flash the UVC file for the correct color camera (ARM is generic, UVC is color dependant)

## APPENDIX A – VISCA SETTINGS AND COMMAND LIST

---

Replace the 'x' in all the '8x' addresses with the serial Visca address set in the camera to control it. When using VISCA over IP the 'x' in all the '8x' addresses is always '1', as the unique identifier is the IP address.

### VISCA over IP

The Avonic IP camera is implemented with a TCP server. The TCP port number is 1259 by default and can be altered in the WebGUI. Once the connection between client and server is set up, the client will be able to send PTZ commands to the server. The server then parses and executes the PTZ command.

The Avonic IP Camera also has an implemented UDP server. The UDP port number is fixed on 1259. Once the connection between client and server is set up, the client will be able to send PTZ commands to the server. The server then parses and executes the PTZ command.

**Pay attention to the fact that the camera does not send back any communication via UDP.**

The VISCA over IP command list is based on the VISCA protocol. Not all VISCA commands are implemented.

The PTZ Command format is according to the definition of the VISCA protocol. The VISCA address of the camera is set to 1 by default and can be changed in the WebGUI. As all cameras are uniquely identified by their IP address, all VISCA serial addresses of the cameras that are controlled over IP do not necessarily have to be unique.

Default settings:

TCP port	1259
UDP port	1259 (same port as TCP; is correct)
VISCA address	1

## 1. Camera return commands

x = Camera Address

y = Socket Number

z = Camera Address + 8

All parameter values are in HEX

Return/complete Command			
Command	Function	Command Packet	Comments
ACK/Completion Messages	ACK	90 4y FF (y: Socket No.)	Return when the command is accepted.
	Completion	90 5y FF (y: Socket No.)	Return when the command has been executed.

Error command			
Command	Function	Command Packet	Comments
Error Messages	Syntax Error	90 60 02 FF	Returned when the command format is different or when a command with illegal command parameters is accepted.
	Command Buffer Full	90 60 03 FF	Indicates that two sockets are already being used (executing two commands) and the command could not be accepted when received.
	Command Canceled	90 6y 04 FF (y: Socket No.)	Returned when a command which is being executed in a socket specified by the cancel command is canceled. The completion message for the command is not returned.
	No Socket	90 6y 05 FF (y: Socket No.)	Returned when no command is executed in a socket specified by the cancel command, or when an invalid socket number is specified.
	Command Not Executable	90 6y 41 FF (y: Execution command Socket No. Inquiry command: 0)	Returned when a command cannot be executed due to current conditions. For example, when commands controlling the focus manually are received during auto focus.

## 2 Camera control commands

x = Camera Address

y = Socket Number

z = Camera Address + 8

All parameter values are in HEX

Camera control commands			
Command	Function	Command Packet	Comments
Address Set	Broadcast	88 30 01 FF	Address setting
CAM_Power	On	8x 01 04 00 02 FF	Power ON
	Off	8x 01 04 00 03 FF	Power OFF
	Reboot	8x 0A 01 06 01 FF	Reboot
CAM_Zoom	Stop	8x 01 04 07 00 FF	
	Tele (Standard speed)	8x 01 04 07 02 FF	
	Wide (Standard speed)	8x 01 04 07 03 FF	
	Tele (Variable speed)	8x 01 04 07 2p FF	p = 0(low speed) - F(high speed)
	Wide (Variable speed)	8x 01 04 07 3p FF	
	Direct	8x 01 04 47 0p 0q 0r 0s FF	pqrs(0-F): Zoom Position
CAM_Focus	Stop	8x 01 04 08 00 FF	
	Far (Standard speed)	8x 01 04 08 02 FF	
	Near (Standard speed)	8x 01 04 08 03 FF	
	Far (Variable speed)	8x 01 04 08 2p FF	p = 0(low) - F(high)
	Near (Variable speed)	8x 01 04 08 3p FF	
	Direct Focus Position	8x 01 04 48 0p 0q 0r 0s FF	min p=0,q=0,r=0,s=0 max p=0,q=6,r=E,s=A
	Auto Focus	8x 01 04 38 02 FF	AF On
	Manual Focus	8x 01 04 38 03 FF	AF Off
	Auto/Manual	8x 01 04 38 10 FF	AF Toggle On/Off
CAM_WB	Auto	8x 01 04 35 00 FF	Normal Auto
	Indoor mode	8x 01 04 35 01 FF	Indoor mode
	Outdoor mode	8x 01 04 35 02 FF	Outdoor mode
	OnePush mode	8x 01 04 35 03 FF	One Push WB mode
	Manual	8x 01 04 35 05 FF	Manual Control mode
	OnePush trigger	8x 01 04 10 05 FF	One Push WB Trigger

Camera control commands			
Command	Function	Command Packet	Comments
Address Set	Broadcast	88 30 01 FF	Address setting
CAM_Bgain	Reset	8x 01 04 04 00 FF	Manual Control of B Gain
	Up	8x 01 04 04 02 FF	
	Down	8x 01 04 04 03 FF	
	Direct	8x 01 04 44 00 00 0p 0q FF	pq: B Gain
CAM_AE	Full Auto	8x 01 04 39 00 FF	Automatic Exposure mode
	Manual	8x 01 04 39 03 FF	Manual Control mode
	Shutter priority	8x 01 04 39 0A FF	Shutter Priority Automatic Exposure mode
	Iris priority	8x 01 04 39 0B FF	Iris Priority Automatic Exposure mode
	Bright	8x 01 04 39 0D FF	Bright Mode(Manual control)
CAM_Iris	Reset	8x 01 04 0B 00 FF	Iris Setting (CAM_AE is set to Iris Priority)
	Up	8x 01 04 0B 02 FF	
	Down	8x 01 04 0B 03 FF	
	Direct Iris Position	8x 01 04 4B 00 00 0p 0q FF	min p = 0 q = 0 max p = 0, q = C
CAM-Shutter	Direct	8x 01 04 4A 00 00 0p 0q FF	min p = 0 q = 0 max p = 1 q = 0
CAM_Gain	Reset	8x 01 04 0C 00 FF	Gain Setting
	Up	8x 01 04 0C 02 FF	
	Down	8x 01 04 0C 03 FF	
	Direct	8x 01 04 0C 00 00 0p 0q FF	pq: Gain Position
	Gain Limit	8x 01 04 2C 0p FF	p: Gain Position
CAM_Bright (only works with exposure mode Bright enabled)	Reset	8x 01 04 0D 00 FF	Bright Setting
	Up	8x 01 04 0D 02 FF	
	Down	8x 01 04 0D 03 FF	
	Direct	8x 01 04 0D 00 00 0p 0q FF	pq: Bright Position
CAM_ExpComp (EV and EV Level)	On	8x 01 04 3E 02 FF	Exposure Compensation On/Off
	Off	8x 01 04 3E 03 FF	
	Reset	8x 01 04 0E 00 FF	Exposure Compensation Amount Setting
	Up	8x 01 04 0E 02 FF	
	Down	8x 01 04 0E 03 FF	
	Direct	8x 01 04 4E 00 00 0p 0q FF	pq: ExpComp Position
CAM_BackLight	On	8x 01 04 33 02 FF	Back Light Compensation On/Off
	Off	8x 01 04 33 03 FF	



## Camera control commands

Command	Function	Command Packet	Comments
Address Set	Broadcast	88 30 01 FF	Address setting
CAM_NR(2D)Mode	Auto	8x 01 04 50 02 FF	NR2D Auto/Manual
	Manual	8x 01 04 50 03 FF	
CAM_NR(2D)Level	-	8x 01 04 53 0p FF	p: NR Setting (0: Off, level 1 to 5)
CAM_NR(3D)Level	-	8x 01 04 54 0p FF	p: NR Setting (0: Off, level 1 to 8)
CAM_Flicker	-	8x 01 04 23 0p FF	p: Flicker Settings (0: Off, 1: 50Hz, 2: 60Hz)
CAM_DHotPixel	-	8x 01 04 56 0p FF	p: Dynamic Hot Pixel Setting (0: Off, level 1 to 6)
CAM_Aperture(sharpness)	Reset	8x 01 04 02 00 FF	Aperture Control
	Up	8x 01 04 02 02 FF	
	Down	8x 01 04 02 03 FF	
	Direct	8x 01 04 42 00 00 0p 0q FF	pq: Aperture Gain
CAM_PictureEffect	Off	8x 01 04 63 00 FF	Picture Effect Setting
	B&W	8x 01 04 63 04 FF	
CAM_Memory (preset)	Reset	8x 01 04 3F 00 pp FF	pp: Memory Number (=0 to 127)
	Set	8x 01 04 3F 01 pp FF	
	Recall	8x 01 04 3F 02 pp FF	
CAM_LR_Reverse	On	8x 01 04 61 02 FF	Image Flip Horizontal On/Off
	Off	8x 01 04 61 03 FF	
CAM_PictureFlip	On	8x 01 04 66 02 FF	Image Flip Vertical On/Off
	Off	8x 01 04 66 03 FF	
Freeze	Freeze ON	8x 04 04 62 02 FF	Freeze ON immediately
	Freeze OFF	8x 04 04 62 03 FF	Freeze OFF immediately
	Preset Freeze ON	8x 04 04 62 22 FF	Freeze ON when running preset
	Preset Freeze OFF	8x 04 04 62 23 FF	Freeze OFF when running preset
SYS_Menu	Off	8x 01 06 06 03 FF	Turns on/off the OSD menu
	On	8x 01 06 06 02 FF	
CAM_ColorGain	Direct	8x 01 04 49 00 00 00 0P FF	p: Color Gain setting 0h (60%) to Eh (200%)

Camera control commands

Command	Function	Command Packet	Comments
<b>Address Set</b>	Broadcast	88 30 01 FF	Address setting
<b>Pan_tiltDrive</b>	Up	8x 01 06 01 VV WW 03 01 FF	VV: Pan speed 0x01 (low speed) to 0x18 (high speed) WW: Tilt speed 0x01 (low speed) to 0x14 (high speed) YYYY: Pan Position ZZZZ: Tilt Position
	Down	8x 01 06 01 VV WW 03 02 FF	
	Left	8x 01 06 01 VV WW 01 03 FF	
	Right	8x 01 06 01 VV WW 02 03 FF	
	Upleft	8x 01 06 01 VV WW 01 01 FF	
	Upright	8x 01 06 01 VV WW 02 01 FF	
	DownLeft	8x 01 06 01 VV WW 01 02 FF	
	DownRight	8x 01 06 01 VV WW 02 02 FF	
	Stop	8x 01 06 01 VV WW 03 03 FF	
	AbsolutePosition	8x 01 06 02 VV WW 0Y 0Y 0Y 0Y 0Z 0Z 0Z 0Z FF	
	RelativePosition	8x 01 06 03 VV WW 0Y 0Y 0Y 0Y 0Z 0Z 0Z 0Z FF	
	Home	8x 01 06 04 FF	
	Reset	8x 01 06 05 FF	
<b>Pan_tiltLimitSet</b>	LimitSet	8x 01 06 07 00 0W 0Y 0Y 0Y 0Y 0Z 0Z 0Z 0Z FF	W: 1 UpRight 0: Down-Left YYYY: Pan Limit Position ZZZZ: Tilt Position
	LimitClear	8x 01 06 07 01 0W 07 0F 0F 0F 07 0F 0F 0F FF	
<b>CAM_AFSensitivity</b>	High	8x 01 04 58 01 FF	AF Sensitivity High/Normal/Low
	Normal	8x 01 04 58 02 FF	
	Low	8x 01 04 58 03 FF	
<b>CAM_SettingReset</b>	Reset	8x 01 04 A0 10 FF	Reset Factory Setting
<b>CAM_Brightness</b>	Direct	8x 01 04 A1 00 00 0p 0q FF	pq: Brightness Position
<b>CAM_Contrast</b>	Direct	8x 01 04 A2 00 00 0p 0q FF	pq: Contrast Position
<b>CAM_Flip</b>	Off	8x 01 04 A4 00 FF	Single Command For Video Flip
	Flip-H	8x 01 04 A4 01 FF	
	Flip-V	8x 01 04 A4 02 FF	
	Flip-HV	8x 01 04 A4 03 FF	
<b>CAM_Autoflip</b>	Autoflip ON	8x 01 02 70 02 FF	Autoflip ON
	Autoflip OFF	8x 01 02 70 03 FF	Autoflip OFF
<b>CAM_SettingSave</b>	Save	8x 01 04 A5 10 FF	Save Current Setting
<b>CAM_Iridix</b>	Direct	8x 01 04 A7 00 00 0p 0q FF	pq: Iridix Position

## Camera control commands

### Camera control commands

Command	Function	Command Packet	Comments
CAM_AWBSensitivity	High	8x 01 04 A9 00 FF	High
	Normal	8x 01 04 A9 01 FF	Normal
	Low	8x 01 04 A9 02 FF	Low
CAM_AFZone	Top	8x 01 04 AA 00 FF	AF Zone weight select
	Center	8x 01 04 AA 01 FF	
	Bottom	8x 01 04 AA 02 FF	
CAM_ColorHue	Direct	8x 01 04 4F 00 00 00 0p FF	p: Color Hue setting 0h (- 14 degrees) to Eh (+14 degrees)
Command	Function	Command Packet	Comments
Pan-tilt_MaxSpeed	High Speed Pan/Tilt ON	8x 0A 01 31 03 FF	High Speed PT ON
	High Speed Pan/Tilt OFF	8x 0A 01 31 02 FF	High Speed PT OFF
ARM/MCU_Version Inq	Inquiry ARM/MCU Version	8x 09 0A 01 03 FF	
CAM/UVC_Version Inq	Inquiry Cam/UVC version	8x 09 00 02 FF	
CAM_TallyLight (Cm7x only with license active)	Red	8x 01 7E 01 0A 00 02 03 FF	Tally Light Red ON
	Green	8x 01 7E 01 0A 00 03 02 FF	Tally Light Green ON
	Off	8x 01 7E 01 0A 00 03 03 FF	Tally Light OFF
Preset_H_Speed	Horizontal (Pan) speed between presets	81 01 03 01 qq FF	qq= speed setting 1 ~ 25 (1 = 00 HEX, 25 = 18 HEX)
Preset_V_Speed	Vertical (Tilt) speed between presets	81 01 03 02 qq FF	qq = speed setting 1 ~ 21 (1 = 00 HEX, 21 = 14 HEX)
Preset_Z_Speed	Zoom speed between presets	81 01 03 03 qq FF	qq = speed setting 1 ~ 8 (1 = 00 HEX, 8 = 07 HEX)
Blue_Tuning (auto whitebalance active)	more or less blue while maintaining auto white balance active	81 0A 01 13 pp FF	pp = setting -10 ~ +10 (00-14 HEX)
Red_Tuning (auto whitebalance active)	more or less red while maintaining auto white balance active	81 0A 01 12 pp FF	pp = setting -10 ~ +10 (00-14 HEX)

## Camera control commands

Command	Function	Command Packet	Comments
VideoSystem_Set		8x 01 06 35 00 pp FF	pp: Video Format 00: 1080p60 01: 1080p50 02: 1080i60 03: 1080i50 04: 720p60 05: 720p50 06: 1080p30 07: 1080p25 08: 720p30 09: 720p25 0A: 1080p59.94 0B: 1080i59.94 0C: 720p59.94 0D: 1080p29.97 0E: 720p29.97

### 3 Inquiry commands

x = Camera Address

y = Socket Number

z = Camera Address + 8

All parameter values are in HEX

Inquiry Command			
Command	Function	Command Packet	Comments
CAM_ZoomPosInq	8x 09 04 47 FF	90 50 0p 0q 0r 0s FF	pqrs: Zoom Position
CAM_FocusAF-ModelInq	8x 09 04 38 FF	90 50 02 FF	Auto Focus
		90 50 03 FF	Manual Focus
CAM_FocusPosInq	8x 09 04 48 FF	90 50 0p 0q 0r 0s FF	pqrs: Focus Position
CAM_WBModelInq	8x 09 04 35 FF	90 50 00 FF	Auto
		90 50 01 FF	Indoor mode
		90 50 02 FF	Outdoor mode
		90 50 03 FF	OnePush mode
		90 50 05 FF	Manual
CAM_RGainInq	8x 09 04 43 FF	90 50 00 00 0p 0q FF	pq: R Gain
CAM_BGainInq	8x 09 04 44 FF	90 50 00 00 0p 0q FF	pq: B Gain
CAM_AEModeInq	8x 09 04 39 FF	90 50 00 FF	Full Auto
		90 50 03 FF	Manual
		90 50 0A FF	Shutter priority
		90 50 0B FF	Iris priority
		90 50 0D FF	Bright
CAM_ShutterPosInq	8x 09 04 4A FF	90 50 00 00 0p 0q FF	pq: Shutter Position
CAM_IrisPosInq	8x 09 04 4B FF	90 50 00 00 0p 0q FF	pq: Iris Position
CAM_BrightPosInq	8x 09 04 4D FF	90 50 00 00 0p 0q FF	pq: Bright Position
Inquiry Command			
Command	Function	Command Packet	Comments
CAM_ExpComp-ModelInq	8x 09 04 3E FF	90 50 02 FF	On
		90 50 03 FF	Off
CAM_ExpCompPosInq	8x 09 04 4E FF	90 50 00 00 0p 0q FF	pq: ExpComp Position
CAM_Backlight-ModelInq	8x 09 04 33 FF	90 50 02 FF	On
		90 50 03 FF	Off
CAM_Noise2DLevel	8x 09 04 53 FF	90 50 0p FF	Noise Reduction (2D) p: 0 to 5
CAM_Noise3DLevel	8x 09 04 54 FF	90 50 0p FF	Noise Reduction (3D) p: 0 to 8
CAM_Flicker-ModelInq	8x 09 04 55 FF	90 50 0p FF	p: Flicker Settings(0: OFF, 1: 50Hz, 2: 60Hz)

Inquiry Command			
CAM_Aperture-ModelInq(Sharpness)	8x 09 04 05 FF	90 50 02 FF	Auto Sharpness
		90 50 03 FF	Manual Sharpness
CAM_ApertureInq(Sharpness)	8x 09 04 42 FF	90 50 00 00 0p 0q FF	pq: Aperture Gain
CAM_PictureEffect-ModelInq	8x 09 04 63 FF	90 50 02 FF	Off / Color
		90 50 04 FF	B&W
CAM_MemoryInq	8x 09 04 3F FF	90 50 0p FF	p: Memory number last operated.
SYS_MenuModelInq	8x 09 06 06 FF	90 50 02 FF	On
		90 50 03 FF	Off
CAM_LR_ReverselInq	8x 09 04 61 FF	90 50 02 FF	On
		90 50 03 FF	Off
CAM_PictureFlipInq	8x 09 04 66 FF	90 50 02 FF	On
		90 50 03 FF	Off
CAM_ColorGainInq	8x 09 04 49 FF	90 50 00 00 00 0p FF	p: Color Gain setting 0h (60%) to Eh (200%)
CAM_BTuningInq	81 09 0A 01 13 FF	90 50 pp FF	pp = setting -10 ~ +10 (00~14 HEX)
CAM_RTuningInq	81 09 0A 01 12 FF	90 50 pp FF	pp = setting -10 ~ +10 (00~14 HEX)
VideoSystemInq	8x 09 06 23 FF	90 50 00 FF	1920x1080p60
		90 50 01 FF	1920x1080p50
		90 50 02 FF	1920x1080i60
		90 50 03 FF	1920x1080i50
		90 50 04 FF	1280x720p60
		90 50 05 FF	1280x720p50
		90 50 06 FF	1920x1080p30
		90 50 07 FF	1920x1080p25
		90 50 08 FF	1280x720p30
		90 50 09 FF	1280x720p25
		90 50 0A FF	1920x1080p59.94
		90 50 0B FF	1920x1080i59.94
		90 50 0C FF	1280x720p59.94
		90 50 0D FF	1920x1080p29.97
90 50 0E FF	1280x720p29.97		
Pan-tiltMaxSpeedInq	8x 09 06 11 FF	90 50 ww zz FF	ww: Pan Max Speed zz: Tilt Max Speed
Pan-tiltPosInq	8x 09 06 12 FF	90 50 0w 0w 0w 0w 0z 0z 0z 0z FF	wwww: Pan Position zzzz: Tilt Position
CAM_GainLimitInq	8x 09 04 2C FF	90 50 0q FF	p: Gain Limit
CAM_DHotPixelInq	8x 09 04 56 FF	90 50 0q FF	p: Dynamic Hot Pixel Setting (0: Off, level 1 to 6)

Inquiry Command			
CAM_AFSensitivityInq	8x 09 04 58 FF	90 50 01 FF	High
		90 50 02 FF	Normal
		90 50 03 FF	Low
CAM_BrightnessInq	8x 09 04 A1 FF	90 50 00 00 0p 0q FF	pq: Brightness Position
CAM_ContrastInq	8x 09 04 A2 FF	90 50 00 00 0p 0q FF	pq: Contrast Position
CAM_FlipInq	8x 09 04 A4 FF	90 50 00 FF	Off
		90 50 01 FF	Flip-H
		90 50 02 FF	Flip-V
		90 50 03 FF	Flip-HV
CAM_IridixInq	8x 09 04 A7 FF	90 50 00 00 0p 0q FF	pq: Iridix Position
CAM_AFZone	8x 09 04 AA FF	90 50 00 FF	Top
		90 50 01 FF	Center
		90 50 02 FF	Bottom
CAM_ColorHueInq	8x 09 04 4F FF	90 50 00 00 00 0p FF	p: Color Hue setting 0h (-14 degrees) to Eh (+14 degrees)
CAM_AWBSensitivityInq	81 09 04 A9 FF	90 50 00 FF	High
		90 50 01 FF	Normal
		90 50 02 FF	Low

Inquiry Command			
Command	Function	Command Packet	Comments
CAM_ZoomPosInq	8x 09 04 47 FF	90 50 0p 0q 0r 0s FF	pqrs: Zoom Position
CAM_FocusAF-Modelnq	8x 09 04 38 FF	90 50 02 FF	Auto Focus
		90 50 03 FF	Manual Focus
CAM_FocusPosInq	8x 09 04 48 FF	90 50 0p 0q 0r 0s FF	pqrs: Focus Position
CAM_WBModelnq	8x 09 04 35 FF	90 50 00 FF	Auto
		90 50 01 FF	Indoor mode
		90 50 02 FF	Outdoor mode
		90 50 03 FF	OnePush mode
		90 50 05 FF	Manual
CAM_RGainInq	8x 09 04 43 FF	90 50 00 00 0p 0q FF	pq: R Gain
CAM_BGainInq	8x 09 04 44 FF	90 50 00 00 0p 0q FF	pq: B Gain
CAM_AEModelnq	8x 09 04 39 FF	90 50 00 FF	Full Auto
		90 50 03 FF	Manual
		90 50 0A FF	Shutter priority
		90 50 0B FF	Iris priority
		90 50 0D FF	Bright
CAM_ShutterPosInq	8x 09 04 4A FF	90 50 00 00 0p 0q FF	pq: Shutter Position
CAM_IrisPosInq	8x 09 04 4B FF	90 50 00 00 0p 0q FF	pq: Iris Position
CAM_BrightPosInq	8x 09 04 4D FF	90 50 00 00 0p 0q FF	pq: Bright Position
CAM_PowerInq	8x 09 04 00 FF	y0 50 02 FF	On
		y0 50 03 FF Off	Off (Standby)



# APPENDIX B – DIMENSIONS

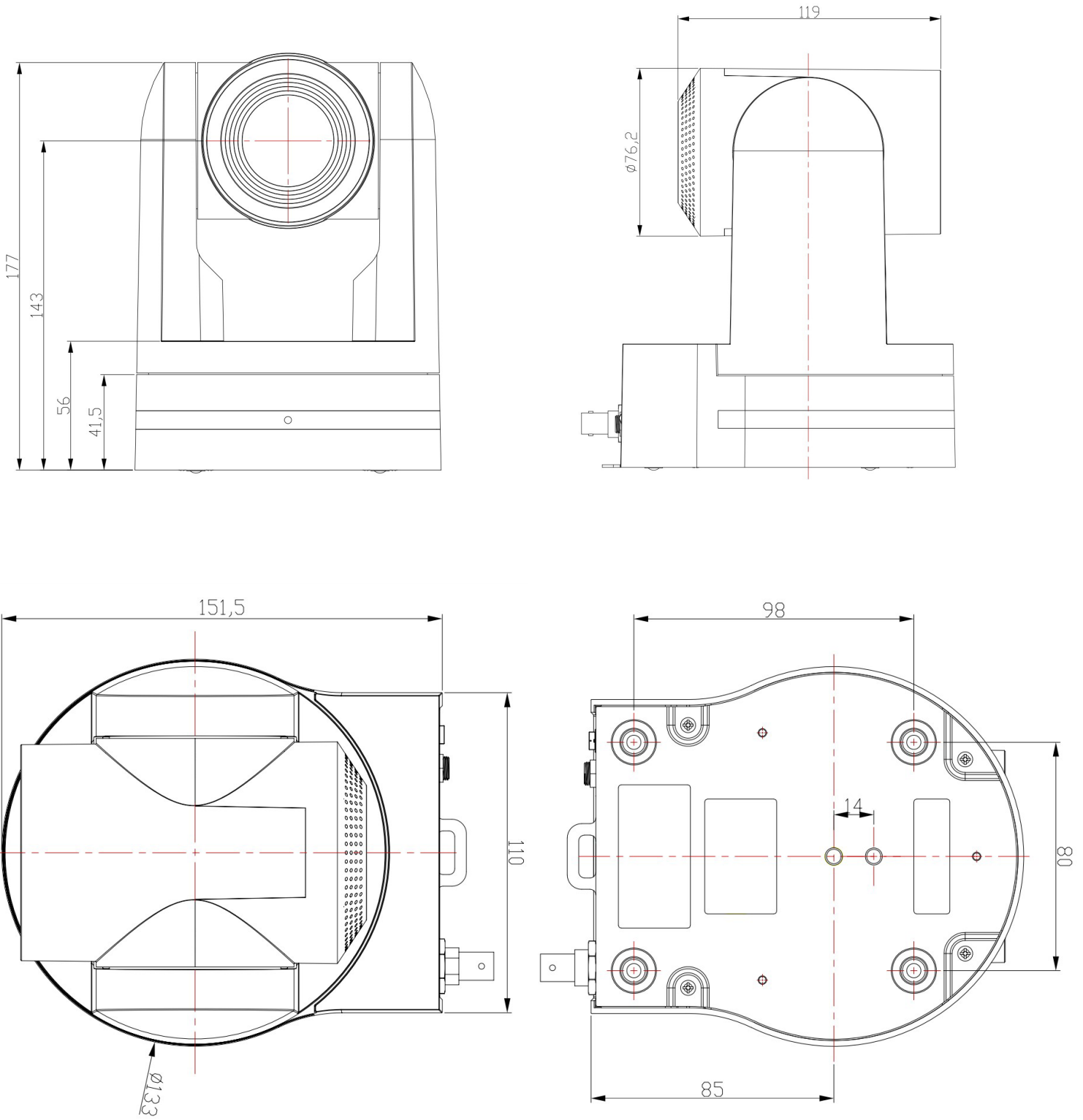

# APPENDIX C – HTTP API

URL format: "http://192.168.5.126/ajaxcom?szCmd="

Note 1: calling the http API, successfully returns {"nRetVal":0, "szError":""}, failed returns {"nRetVal":-1879048185, "szError":""}

Note 2: No spaces are allowed in the key values when using the API

Note 3: depending on the client used to send the commands, minor adjustments need to be applied. For example, when using cURL from the windows command line interface, quotation marks need to be doubled, while the API lists: {"SysCtrl":{"PtzCtrl":{"nChanel":0,"szPtzCmd":"preset\_set","byValue":0}}}

The correct cURL command would be:

```
curl "http://192.168.5.163/ajaxcom" --data-raw "szCmd={\"SysCtrl\":{\"PtzCtrl\":{\"nChanel\":0,\"szPtzCmd\":\"preset_call\",\"byValue\":0}}}"
```

1 PTZ			
Code	http://192.168.5.126/ajaxcom?szCmd={"SysCtrl":{"PtzCtrl":{"nChanel":0,"szPtzCmd":"left_start","byValue":50}}}		
Command	setting	Function	Command
nChanel	0		
byValue	0, 100 used to control the speed of ptz		
szPtzCmd			
		left start	left_start
		left stop	left_stop
		left up start	leftup_start
		left up stop	leftup_stop
		left down start	leftdown_start
		left down stop	leftdown_stop
		right start	right_start
		right stop	right_stop
		right up start	rightup_start
		right down start	rightdown_start
		right down stop	rightdown_stop
		up start	up_start
		up stop	up_stop
		down start	down_start
		down stop	down_stop
		goto home position	go_home

Focus Mode			
<i>Focus Mode</i>			
Code	{“SetEnv”:{“VideoParam”:[{“stAF”:{“emAFMode”:3,“nChannel”:0}}]}		
<b>Command</b>	<b>Setting</b>		
nChanel	0		
emAFMode	2: Auto		
	3: Manual		
	4 OnePush		
<i>Zoom and focus</i>			
Code	{“SysCtrl”:{“PtzCtrl”:{“nChanel”:0,“szPtzCmd”:“zoomdec_start”,“byValue”:0}}}		
<b>Command</b>	<b>setting</b>	<b>function</b>	<b>command</b>
nChanel	0		
byValue	0		
szPtzCmd			
		Zoom add start	zoomadd_start
		Zoom add stop	zoomadd_stop
		Zoom decrease start	zoomdec_start
		Zoom decrease stop	zoomdec_stop
		Focus add start	focusadd_start
		Focus add stop	focusadd_stop
		Focus decrease start	focusdec_start
		Focus decrease stop	focusdec_stop

Preset			
Code	{“SysCtrl”:{“PtzCtrl”:{“nChanel”:0,“szPtzCmd”:“preset_set”,“byValue”:0}}}		
<b>command</b>	<b>setting</b>	<b>function</b>	<b>command</b>
nChanel	0		
ByValue	0, 254		
szPtzCmd			
		Set preset	preset_set
		Call preset	preset_call
		Clean preset	preset_clean

Audio Configure			
Code	{"SysCtrl":{"PtzCtrl":{"nChanel":0,"szPtzCmd":"preset_set","byValue":0}}}		
Get audio configure			
Code	{"GetEnv":{"Audio":{}}}		
Set audio configure			
Code	{"SetEnv":{"Audio":{"nSampleBits":16,"nAudioSmstMask":[33554888,33554888,33554433],"bEnable":0,"nInpVolume":4,"nBitRate":64,"nAEncType":7,"byAudioCodecList":[6,7,2],"nSampleRate":44100,"nChannel":1}}}		
Function	code	command	setting
Enable	{"SetEnv":{"Audio":{"bEnable":1}}}	bEnable	0: off 1: on
Encode Type	{"SetEnv":{"Audio":{"nAEncType":7}}}	nAEncType	6: Mp3 7: AAC 2: G.711A
Sample Rate	{"SetEnv":{"Audio":{"nSampleRate":32000}}}	nSampleRate (Only supporting these samplerrates and gylla can only be 8000.)	16000 32000 44100 48000
Sample Bits	{"SetEnv":{"Audio":{"nSampleBits":16}}}	nSampleBits	16
Bit Rate	{"SetEnv":{"Audio":{"nBitRate":96}}}	nBitRate	32 48 64 96 128
Channel	{"SetEnv":{"Audio":{"nChannel":2}}}	nChannel	1: Mono 2: Stereo
Input Volume	{"SetEnv":{"Audio":{"nInpVolume":5}}}	nInpVolume (range from 1 to 10.)	Exp:[1, 10]

Video Configure	
Video Encode	
Get video encode parameters	
Code	{"GetEnv":{"VideoEncode":{"nChannel":-1}}}
Set video encode parameters	
Code	{"SetEnv":{"VideoEncode":[{"stSlave":{"byIframeMinQP":20,"byImageQuality":1,"szStreamName":"live/av1","dwVideoCodecMask":160,"emBitRateCtrl":0,"byImageSizeList":[26,7,9,27,4,5],"dwMaxBitRate":40960,"nFrameRate":25,"nMaxFrameRate":30,"emVideoCodec":5,"nIframeInterval":75,"emImageSize":27,"nBitRate":512,"byProfile":2},"stMaster":{"byIframeMinQP":20,"byImageQuality":0,"szStreamName":"live/av0","dwVideoCodecMask":160,"emBitRateCtrl":0,"byImageSizeList":[5,4,9],"dwMaxBitRate":40960,"nFrameRate":25,"nMaxFrameRate":60,"emVideoCodec":5,"nIframeInterval":75,"emImageSize":5,"nBitRate":4096,"byProfile":2},"nChannel":0}]}}

Function	code	command	setting
Compressed Format	<code>{"SetEnv":{"VideoEncode":[{"stMaster":{"emVideoCodec":5,"nChannel":0}]}}</code>	emVideoCodec	5: H.264 7: H.265 (Profile only supports BP profile)
Profile	<code>{"SetEnv":{"VideoEncode":[{"stMaster":{"byProfile":0,"nChannel":0}]}}</code>	byProfile	0: BP 1: MP 2: HP
	<code>{"GetEnv":{"VideoEncode":{"nChannel":-1}}</code>  Compared to webpage and this you can know the different value meaning different image size.	byImageSize-List (Lists all image size, different products have different image size)	
Image Size	<code>{"SetEnv":{"VideoEncode":[{"stMaster":{"emImageSize":4,"nChannel":0}]}}</code>	ImageSize	5: 1920*1080 4: 1280*720 9: 640*480 27: 320*180 26: 640*360
Rate Control	<code>{"SetEnv":{"VideoEncode":[{"stMaster":{"emBitRateCtrl":1,"nChannel":0}]}}</code>	emBitRateCtrl	0: CBR 1: VBR
Image Quality	<code>{"SetEnv":{"VideoEncode":[{"stMaster":{"byImageQuality":5,"nChannel":0}]}}</code>	byImageQuality	0: Low quality 1: 2: 3: 4: 5: Best quality
Bit Rate (kb/s)	<code>{"SetEnv":{"VideoEncode":[{"stMaster":{"dwMaxBitRate":200,"nChannel":0}]}}</code>	dwMaxBitRate	[64 - 40960]
Frame Rate (F/S)	<code>{"SetEnv":{"VideoEncode":[{"stMaster":{"nFrameRate":25,"nChannel":0}]}}</code>	nFrameRate	[5 - 60]
Frame Interval	<code>{"SetEnv":{"VideoEncode":[{"stMaster":{"nIFrameInterval":70,"nChannel":0}]}}</code>	nIFrameInterval	[1 - 300]
Frame Min QP	<code>{"SetEnv":{"VideoEncode":[{"stMaster":{"byIFrameMinQP":70,"nChannel":0}]}}</code>	byIFrameMinQP	[10 - 51]
Stream Name	<code>{"SetEnv":{"VideoEncode":[{"stMaster":{"szStreamName":"live/av01","nChannel":0}]}}</code>	szStreamName	user-defined

### Stream Publish

#### Get stream publish parameters

Code `{"GetEnv":{"StreamPublish":{"nChannel":-1}}`

#### Set stream publish parameters

Code `"SetEnv":{"StreamPublish":[{"stSlave":{"wHostPort":1935,"szHostUrl":"192.168.5.11","nProtoType":2,"szStreamName":"live/av1","bEnable":0,"nAbProtolMask":1,"szSrtKey":"","wSrtKeyLen":0,"szUserName":"","szPassword":"","stMaster":{"wHostPort":1935,"szHostUrl":"192.168.5.11","nProtoType":3,"szStreamName":"live/av0","bEnable":0,"nAbProtolMask":1,"szSrtKey":"111111111","wSrtKeyLen":0,"szUserName":"","szPassword":"","nChannel":0}]}}`

**Note:** When modifying one param, you should always include wHostPort and nProtoType, otherwise, both will be set to zero.

Function	code	command	setting
Enable	<code>{"SetEnv":{"StreamPublish":[{"st-Master":{"wHostPort":1935,"bEnable":1,"nProtolType":3},"nChannel":0}]}}</code>	bEnable	0: off 1: on
Protol Type		nProtolType	2: srt 3: rtmp
Host Address	<code>{"SetEnv":{"StreamPublish":[{"st-Master":{"wHostPort":1935,"nProtolType":3,"szHostUrl":"192.168.5.12"},"nChannel":0}]}}</code>	szHostUrl	user-defined
Host Port	<code>{"SetEnv":{"StreamPublish":[{"st-Master":{"wHostPort":19355,"nProtolType":3},"nChannel":0}]}}</code>	wHostPort	[0 - 65535]
Stream Name	<code>{"SetEnv":{"StreamPublish":[{"st-Master":{"wHostPort":19355,"nProtolType":3,"szStreamName":"live/1213"},"nChannel":0}]}}</code>	szStreamName	user-defined
User Name	<code>{"SetEnv":{"StreamPublish":[{"st-Master":{"wHostPort":19355,"nProtolType":3,"szUserName":"123"},"nChannel":0}]}}</code>	szUserName	user-defined
Password	<code>{"SetEnv":{"StreamPublish":[{"st-Master":{"wHostPort":19355,"nProtolType":3,"szPassword":"123"},"nChannel":0}]}}</code>	szPassword	user-defined
SrtKey(SRT Effectie)	<code>{"SetEnv":{"StreamPublish":[{"st-Master":{"wHostPort":19355,"nProtolType":3,"szSrtKey":"0123456789"},"nChannel":0}]}}</code>	szSrtKey	user-defined
SrtKeyLen(SRT Effectie)	<code>{"SetEnv":{"StreamPublish":[{"st-Master":{"wHostPort":19355,"nProtolType":3,"wSrtKeyLen":"0"},"nChannel":0}]}}</code>	wSrtKeyLen	[0-32]

## RTP Multicast

### Get rtp multicast parameters

Code `{"GetEnv":{"StreamRTPMulticast":{"nChannel":-1}}}`

### Set rtp multicast parameters

Code `{"SetEnv":{"StreamRTPMulticast":[{"stSlave":{"nProtolType":0,"bEnable":0,"wMultiCastPort":4002,"szMultiCastUrl":"224.1.2.3"},"stMaster":{"nProtolType":1,"bEnable":0,"wMultiCastPort":4000,"szMultiCastUrl":"224.1.2.3"},"nChannel":0}]}}`

Note: When modifying one param you should take along bEnable and awMultiCastPort, otherwise it will be set to 0.

Suggesting that when setting env, you can distinguish the stMaster and stSlave.

Function	code	command	setting
Enable	{"SetEnv":{"StreamRTPMulticast":[{"st-Master":{"bEnable":1,"wMultiCastPort":4004,"nChannel":0}]}}	bEnable	0: off 1: on
Protol Type	{"SetEnv":{"StreamRTPMulticast":[{"st-Master":{"bEnable":1,"nProtolType":1,"wMultiCastPort":4004,"nChannel":0}]}}	nProtolType	0: RTP 1: TS
Multicast Ad- dress	{"SetEnv":{"StreamRTPMulticast":[{"st-Master":{"bEnable":0,"szMultiCastUr-l":"224.1.2.23","wMultiCastPort":4004,"nChannel":0}]}}	SzMultiCastUrl	224.0.0.0 ~ 255.255.255.0
Multicast Port	{"SetEnv":{"StreamRTPMulticast":[{"st-Master":{"bEnable":1,"wMultiCastPort":4004,"nChannel":0}]}}	wMultiCastPort	user defined

Video Parameters			
Get video parameters			
Code	{"GetEnv":{"VideoParam":{"nChannel":-1}}}		
Set set video parameters			
Focus			
Function	code	command	setting
Focus Mode	{"SetEnv":{"VideoParam":[{"stAF":{"emAF-Mode":2,"nChannel":0}]}}	emAFMode	2: Auto 3: Manul 4: OnePush
AF-Zone	{"SetEnv":{"VideoParam":[{"stAF":{"emAFZone":1,"nChannel":0}]}}	emAFZone	0: Top 1: Center 2: Bottom 3: All
AF-Sensitivity	{"SetEnv":{"VideoParam":[{"stAF":{"nSen-sitivity":1,"nChannel":0}]}}	nSensitivity	1: High 2: Middle 3: Low
Exposure			
Mode	{"SetEnv":{"VideoParam":[{"stExp":{"stExp-mode":{"emExpMode":0},"nChan-nel":0}]}}	emExpMode	0: Auto 3: Manual 10: SAE 11: AAE 13: Bright
Auto EV	{"SetEnv":{"VideoParam":[{"stExp":{"exp-comp_mode":2,"nChannel":0}]}}	expcomp_mode	2: ON 3: OFF
EV Level	{"SetEnv":{"VideoParam":[{"stExp":{"exp-comp":8,"nChannel":0}]}}	Expcomp	[0 - 14]
BLC	{"SetEnv":{"VideoParam":[{"stExp":{"-backlight":2,"nChannel":0}]}}	backlight	2: ON 3: OFF

Video Parameters			
Exposure			
Function	code	command	setting
Flicker	{"SetEnv":{"VideoParam":[{"stExp":{"antiflicker":0,"nChannel":0}]}}	antiflicker	0: OFF 1: 50HZ 2: 60HZ
G.Limit	{"SetEnv":{"VideoParam":[{"stExp":{"gainLimit":5,"nChannel":0}]}}	gainLimit	[0 - 15]
DRC	{"SetEnv":{"VideoParam":[{"stExp":{"drc":6,"nChannel":0}]}}	drc	[0 - 8]
Manual/shutter	{"SetEnv":{"VideoParam":[{"stExp":{"stShutter":{"nShutter":16},"nChannel":0}]}}	nShutter	[0 - 16]
Iris	{"SetEnv":{"VideoParam":[{"stExp":{"stIris":{"nIris":12},"nChannel":0}]}}	nIris	[0 - 12]
DRC	{"SetEnv":{"VideoParam":[{"stExp":{"drc":8,"nChannel":0}]}}	drc	[0 - 8]
SAE shutter speed	{"SetEnv":{"VideoParam":[{"stExp":{"stShutter":{"nShutter":16},"nChannel":0}]}}	nShutter	[0 -16]
DRC	{"SetEnv":{"VideoParam":[{"stExp":{"drc":7,"nChannel":0}]}}	drc	[0, 8]
AEE Flicker	{"SetEnv":{"VideoParam": [{"stExp":{"antiflicker":0,"nChannel":0}]}}	Antiflicker	0: OFF 1: 50HZ 2: 60HZ
G.Limit	{"SetEnv":{"VideoParam":[{"stExp":{"gainLimit":5,"nChannel":0}]}}	gainLimit	[0 - 15]
Iris	{"SetEnv":{"VideoParam":[{"stExp":{"stIris":{"nIris":12},"nChannel":0}]}}	nIris	[0 - 12]
DRC	{"SetEnv":{"VideoParam": [{"stExp":{"drc":6,"nChannel":0}]}}	drc	[0 - 8]
Bright	{"SetEnv":{"VideoParam":[{"stExp":{"bright":0,"nChannel":0}]}}	bright	[0 - 23]
Color			
Function	code	command	setting
WB Mode	{"SetEnv":{"VideoParam":[{"stColor":{"stWbMode":{"emWbMode":0},"nChannel":0}]}}	emWbMode	0: Auto 1: 3000K 7: 3500K 2: 4000K 8: 4500K 4: 5000K 9: 5500K 10: 6000K 6: 6500K 11: 7000K 5: Manuak 3: OnePush



Video Parameters			
Color			
Function	code	command	setting
RG Tuning	{"SetEnv":{"VideoParam":[{"stColor":{"rgaintuning":0},"nChannel":0}]}}	rgaintuning	[0 - 20]
BG Tuning	{"SetEnv":{"VideoParam":[{"stColor":{"bgaintuning":20},"nChannel":0}]}}	bgaintuning	[0 - 20]
Saturation	{"SetEnv":{"VideoParam":[{"stColor":{"saturation":0},"nChannel":0}]}}	saturation	[0 -14]
Hue	{"SetEnv":{"VideoParam":[{"stColor":{"hue":14},"nChannel":0}]}}	hue	[0 -14]
AWB Sensitivity	{"SetEnv":{"VideoParam":[{"stColor":{"awbsens":0},"nChannel":0}]}}	awbsens	0: Low 1: Middle 2: High
Image			
Bright	{"SetEnv":{"VideoParam":[{"stImg":{"luminance":0},"nChannel":0}]}}	luminance	[0 - 14]
Contrast	{"SetEnv":{"VideoParam":[{"stImg":{"contrast":0},"nChannel":0}]}}	contrast	[0 - 14]
Sharpness	{"SetEnv":{"VideoParam":[{"stImg":{"sharpness":1},"nChannel":0}]}}	sharpness	[0 - 15]
Gamma	{"SetEnv":{"VideoParam":[{"stImg":{"gamma":0},"nChannel":0}]}}	gamma	[0 -4] 0: Default 1: 0.45 2: 0.50 3: 0.55 4: 0.63
DCI	{"SetEnv":{"VideoParam":[{"stImg":{"dci":0},"nChannel":0}]}}	dci	[0 - 8] 0: OFF
B&W Mode	{"SetEnv":{"VideoParam":[{"stImg":{"nB-WMode":0},"nChannel":0}]}}	nBWMode	0: Color 4: B & W
Flip-H	{"SetEnv":{"VideoParam":[{"stImg":{"n-FlipH":3},"nChannel":0}]}}	nFlipH	2: ON 3: OFF
Flip-V	{"SetEnv":{"VideoParam":[{"stImg":{"n-FlipV":2},"nChannel":0}]}}	nFlipV	2: ON 3: OFF
DZoom	{"SetEnv":{"VideoParam":[{"stImg":{"nE-Zoom":3},"nChannel":0}]}}	nEZoom	2: ON 3: OFF
NR			
NR-3D	{"SetEnv":{"VideoParam":[{"stNR":{"noise3D":0},"nChannel":0}]}}	noise3D	[0, 8] 0: OFF 8: Auto
Dynamic Hot Pixel	{"SetEnv":{"VideoParam":[{"stNR":{"dhotpixel":3},"nChannel":0}]}}	dhotpixel	[0 - 5] 0: OFF
Style	{"SetEnv":{"VideoParam":[{"stColor":{"nStyleInx":0},"nChannel":0}]}}	nStyleInx	[0 - 4] 0: Default 1: Normal 2: Clarity 3: Bright 4: Soft

Video OSD	
<b>Get video parameters</b>	
Code	{ "GetEnv": { "VideoOsd": { "nChannel": -1 } } }
<b>Set set video parameters</b>	
Code	{ "SetEnv": { "VideoOsd": [ { "stTime": { "bEnable": 1, "nIndex": 0, "nXPos": 0, "szText": "", "nYPos": 10000, "stFtColor": { "byAlpha": 128, "byRed": 255, "byGreen": 255, "byBlue": 255 }, "stBkColor": { "byAlpha": 0, "byRed": 0, "byGreen": 0, "byBlue": 0 } }, { "stTitle": { "bEnable": 0, "nIndex": 0, "nXPos": 0, "szText": "", "nYPos": 0, "stFtColor": { "byAlpha": 128, "byRed": 255, "byGreen": 255, "byBlue": 255 }, "stBkColor": { "byAlpha": 0, "byRed": 0, "byGreen": 0, "byBlue": 0 } } ], "nChannel": 0 } } }

Note: All parameters can be saved by this command and also you can set one param alone.

Function	code	command	setting
Show Time	{ "SetEnv": { "VideoOsd": [ { "stTime": { "bEnable": 1, "nChannel": 0 } } ] }	bEnable	0: Not show 1: Show
Show Title	{ "SetEnv": { "VideoOsd": [ { "stTitle": { "bEnable": 1, "nChannel": 0 } } ] }	bEnable	0: Not Show 1: Show
Time Font Color	{ "SetEnv": { "VideoOsd": [ { "stTime": { "stFtColor": { "byAlpha": 128, "byRed": 255, "byGreen": 255, "byBlue": 0 } }, "nChannel": 0 } } ] }	byAlpha	128
		white	rgb (255,255,255)
		black	rgb (0,0,0)
		yellow	rgb (255,255,0)
		red	rgb (255,0,0)
Title Font Color	{ "SetEnv": { "VideoOsd": [ { "stTitle": { "stFtColor": { "byAlpha": 128, "byRed": 255, "byGreen": 255, "byBlue": 0 } }, "nChannel": 0 } } ] }	byAlpha	128
		white	rgb (255,255,255)
		black	rgb (0,0,0)
		yellow	rgb (255,255,0)
		red	rgb (255,0,0)
OSD Offset x pos	Time: { "SetEnv": { "VideoOsd": [ { "stTime": { "nXPos": 9200, "nChannel": 0 } } ] }	nXPos	[0, 10000]
	Title: { "SetEnv": { "VideoOsd": [ { "stTitle": { "nXPos": 9200, "nChannel": 0 } } ] }		
OSD Offset y pos	Time: { "SetEnv": { "VideoOsd": [ { "stTime": { "nYPos": 1200, "nChannel": 0 } } ] }	nYPos	[0, 10000]
	Title: { "SetEnv": { "VideoOsd": [ { "stTitle": { "nYPos": 1200, "nChannel": 0 } } ] }		

OSD Font Size			
<b>Get osd font size parameters</b>			
Code	{ "GetEnv": { "TTFFontSize": { "nChannel": -1 } } }		
<b>Set video parameters</b>			
Code	{ "SetEnv": { "TTFFontSize": { "nFontSize": [48,48], "bAutoSize": 1 } } }		
Function	code	command	setting
		bAutoSize	0: off, 1: on
		nFontSize	[8,200]

Video Out			
<b>Get video out parameters</b>			
Code	{"GetEnv":{"VideoOut":{"nChannel":-1}}}		
<b>Set video out parameters</b>			
Code	{"SetEnv":{"VideoOut":{"nNetMode":2,"emVoutFormat":9,"byFormatList":[10,9,4,3,8,7,6,5,26,25,20,21,22,23,24]}}		
Function	code	command	setting
		nNetMode: default value 2, do not modify it	0 – HD output 1 – HD output + SD network 2 – SD output + HD network
		emVoutFormat: Setting the current video out format.	10: 1080P60 9: 1080P50 4: 1080P30 3: 1080P25 8: 1080I60 7: 1080I50 6: 720P60 5: 720P50 26: 720P30 25: 720P25 20: 1080P59.94 21: 1080I59.94 22: 1080P29.97 23: 720P59.94 24: 720P29.97

SRT			
<b>Get network SRT parameters</b>			
Code	{"GetEnv":{"NetWork":{"nChannel":-1}}}		
<b>Set network SRT parameters</b>			
Code	{"SetEnv":{"NetWork":{"stSrt":{"wSrtLen":0,"wSrtPort":9000,"szSrtPin":"xxxxxxxxxx"}}}}		
Function	code	command	setting
crypto key length in bytes		wSrtLen	[0-32]
Port SRT		wSrtPort	Default 9000
Password stream encryption		szSrtPin	user-defined

Network Configure			
<b>Get network port parameters</b>			
Code	{"GetEnv":{"NetWork":{"nChannel":-1}}}		
<b>Set network port parameters</b>			
Code	{"SetEnv":{"NetWork":{"stNetPort":{"wPortSoap":1936,"wPortData":3000,"wPortWeb":80,"wPortRtsp":554,"wPortVisca":1259,"wPortOnvif":2000,"wPortRtmp":1935}}}}		
	You can also set one of them like this: {"SetEnv":{"NetWork":{"stNetPort":{"wPortSoap":1936}}}}		
Port Settings			
Function	code	command	setting
Port Data		wPortData	[0, 65535]
Port Web		wPortWeb	[0, 65535]
Port Onvif		wPortOnvif	[0, 65535]
Port Soap		wPortSoap	[0, 65535]
Port Rtmp		wPortRtmp	[0, 65535]
Port Rtsp		wPortRtsp	[0, 65535]
Port Visca		wPortVisca	[0, 65535]
<b>Ethernet</b>			
<b>Get ethernet parameters</b>			
Code	{"GetEnv":{"NetWork":{"nChannel":-1}}}		
<b>Set ethernet parameters</b>			
Code	{"SetEnv":{"NetWork":{"stEth":[{"byValid":5,"szIPAddr":"192.168.5.126","szSubMask":"255.255.255.0","szMacAddr":"E4:77:D4:01:8A:49","szGateway":"192.168.5.1","bDefault":1}]}}}		
Function	code	command	setting
DHCP	{"SetEnv":{"NetWork":{"stEth":[{"byValid":5}]}}}	byValid	5: off 7: on
IP Address	{"SetEnv":{"NetWork":{"stEth":[{"szIPAddr":"192.168.5.127"}]}}}		
Subnet Mask	{"SetEnv":{"NetWork":{"stEth":[{"szSubMask":"255.255.255.0"}]}}}		
Default Gateway	{"SetEnv":{"NetWork":{"stEth":[{"szGateway":"192.168.5.1"}]}}}		
<b>DSN</b>			
<b>Get dsn parameters</b>			
Code	{"GetEnv":{"NetWork":{"nChannel":-1}}}		
<b>Set dsn parameters</b>			
Code	{"SetEnv":{"NetWork":{"stDns":{"szDns1":"8.8.8.8","szDns2":"0.0.0.0"}}}}		
Function	Code	command	setting
Preferred DNS Server	{"SetEnv":{"NetWork":{"stDns":{"szDns1":"8.8.8.8"}}}}		
Alternative DNS Server	{"SetEnv":{"NetWork":{"stDns":{"szDns2":"8.8.8.8"}}}}		

System Configure			
Get syattr parameters			
Code	{"GetEnv":{"SysAttr":{"nChannel":-1}}}		
Set syattr parameters			
Code	{"SetEnv":{"SysAttr":{"nLanguage":0,"szDeviceID":1,"emVideoStandard":1,"szDevName":"testname"}}}		
Function	Code	command	setting
Device Name		szDevName	used-define, cannot use white space
Device ID		szDeviceID	cannot modify
Language		nLanguage	0: Simplified Chinese 2: English

License	
Get License parameters	
Code	:"QueryState":{"QueryLicenseState":{}}}
Set License parameters	
Code	{"SetEnv":{"LicenseKey":{"bLicenseEnable":0,"szKeyText":"483B4EBID0"}}}

SysTime			
Get system time parameters			
Code	{"QueryState":{"QuerySysTime":{}}}		
Set system time parameters			
Code	{"SetEnv":{"SysTime":{"nDateSprtr":2,"nDateFormat":0,"nZone":1,"nHourType":0,"stNtp":{"bEnable":1,"nHostPort":123,"nUpdateInterval":2,"szHostUrl":"ntp4.aliyun.com"}}}}		
Function	Code	command	setting
Date Format	{"SetEnv":{"SysTime":{"nDateFormat":0}}}	nDateFormat	0: YYYY-MM-DD 1: MM-DD-YYYY 2: DD-MM-YYYY
Date Sprtr	{"SetEnv":{"SysTime":{"nDateSprtr":0}}}	nDateSprtr	0: . 1: - 2: /
Zone	{"SetEnv":{"SysTime":{"nZone":0}}}	nZone	[0, 32] 0: GMT 1: GMT+01:00 2: GMT+02:00 3: GMT+03:00 4: GMT+03:30 5: GMT+04:00 6: GMT+04:30 7: GMT+05:00 ..... 13: GMT+08:00 ..... 20: GMT-01:00 ..... 31: GMT-11:00 32: GMT-12:00

SysTime			
Function	Code	command	setting
Hour Type	{"SetEnv":{"SysTime":{"nHourType":0}}}	nHourType	0: 24 Hours 1: 12 Hours
NTP Enable	{"SetEnv":{"SysTime":{"stNtp":{"bEnable":1}}}}	bEnable	0: off 1: on
Update Interval	{"SetEnv":{"SysTime":{"stNtp":{"nUpdateInterval":2}}}}	nUpdateInterval	[1 - 10]
Host URL	{"SetEnv":{"SysTime":{"stNtp":{"szHostUrl":"time.nist.gov"}}}}	szHostUrl	user-defined, ntp server address
Host Port	{"SetEnv":{"SysTime":{"stNtp":{"nHostPort":123}}}}	nHostPort	user-defined: [0, 65535]
Time Settings	Synchronize with computer time or set manual:  {"SysCtrl":{"SetTime":{"bTimeType":1,"nZone":19,"stDateTime":{"dwYear":2018,"byHour":15,"byMinute":38,"byDay":1,"byMonth":11,"bySecond":2}}}}		
Synchronize with NTP Server	{"SysCtrl":{"SyncNtp":""}}		

SysUser			
Get sysuser parameters			
Code	{"GetEnv":{"SysUser":{}}}		
Set sysuser parameters			
Code	{"SetEnv":{"SysUser":{"stUsers":[{"nUserType":0,"szUserName":"admin","szPassword":"admin"}, {"nUserType":1,"szUserName":"user1","szPassword":"user1"}, {"nUserType":1,"szUserName":"user2","szPassword":"user2"}]}}}		
Function	Code	command	setting
Authority		nUserType	0: admin 1: user1 or user 2
User Name		szUserName	user-define: do not use white space
Password		szPassword	user-define, do not use white space  Note: This command must set all three users at the same time.

Update	
Get current firmware parameters	
Code	<code>{"QueryState":{"QueryVersion":{}}}</code>
Code	<p>Get the return value and split it like this:</p> <pre>szText.Format("%d.%d.%d %d-%d-%d", (stVersion.dwCamVersion &gt;&gt; 16) &amp; 0xFF, (stVersion.dwCamVersion &gt;&gt; 8) &amp; 0xFF, (stVersion.dwCamVersion &amp; 0xFF), (stVersion.dwCamDate &gt;&gt; 16) &amp; 0xFFFF, (stVersion.dwCamDate &gt;&gt; 8) &amp; 0xFF, (stVersion.dwCamDate &amp; 0xFF));</pre>

Default	
Code	<code>{"SysCtrl":{"Default":{}}}</code>

Reboot	
Code	<code>{"SysCtrl":{"Reboot":{}}}</code>

# CMOS IMAGE SENSORS CHARACTERISTICS

---

The following occurrences that may appear in images are specific to CMOS (Complementary Metal Oxide Semiconductor) image sensors. They do not indicate malfunctions.

## White flecks

Although the CMOS image sensors are produced with high-precision technologies, fine white flecks may be generated on the screen in rare cases, caused by natural and/or artificial radiation, which causes a “false exposure” on the image sensor. The shape of these spots may vary from dots to lines or other, sometimes irregular shapes. These spots occur in random locations of the image, last only for a single frame and are more visible in dark images. This is a principle issue of all image sensors and not a malfunction.

The white flecks especially tend to be seen in the following cases:

- when operating at a high ambient temperature
- when you have raised the gain (sensitivity)

The white flecks may be reduced by turning the camera off, then on again.

## Aliasing

When fine patterns, stripes, or lines are shot, they may appear jagged or flicker. Aliasing refers to the effect produced when a signal is imperfectly reconstructed from the original signal. Aliasing occurs when a signal is not sampled at a high enough frequency to create an accurate representation. This effect is shown in the following example of a sinusoidal function:

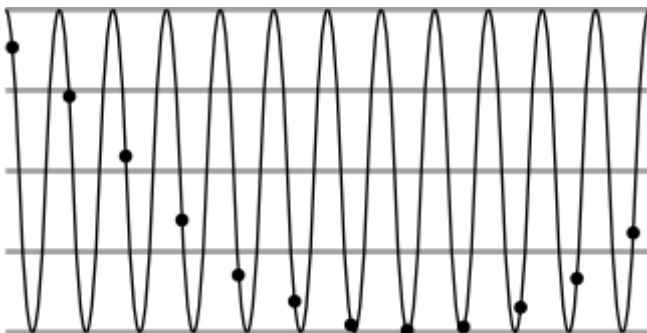

In this example, the dots represent the sampled data and the curve represents the original signal. Because there are too few sampled data points, the resulting pattern produced by the sampled data is a poor representation of the original.



### Focal plane

Owing to the characteristics of the pickup elements (CMOS image sensors) for reading video signals, subjects that quickly move across the screen may appear slightly skewed. Since a CMOS sensor typically captures a row at a time within approximately 1/60th or 1/50th of a second (depending on refresh rate) it may result in a “rolling shutter” effect, where the image is skewed (tilted to the left or right, depending on the direction of camera or subject movement).

### Flash band

If you film a strobe or quick-flashing light, brightness may differ between the upper and lower halves of the picture. See the Focal Plane explanation above for clarification of this occurrence.

### Flicker

If recording under lighting produced by discharge tubes, such as fluorescent, sodium, or mercury-vapor lamps, the screen may flicker, colours may vary, or horizontal stripes may appear distorted. In such cases, turn the anti-flicker setting on. Depending on lighting types, such occurrences may not be improved with the antiflicker setting. It is recommended to set the shutter speed to 1/100 sec. in the areas of 50 Hz power supply frequency and to 1/60 in the areas of 60 Hz.